



SPARE PARTS LIST

FLOOR SAWS

FS513/FS520/FS524, Valid for Machine numbers FS520-2150, FS524-1630 and forward, 2011-02

BATTERY & COVERS 20, 24 HP ONLY

B1 - To Starter Solenoid
B2 - Ground to Engine Block

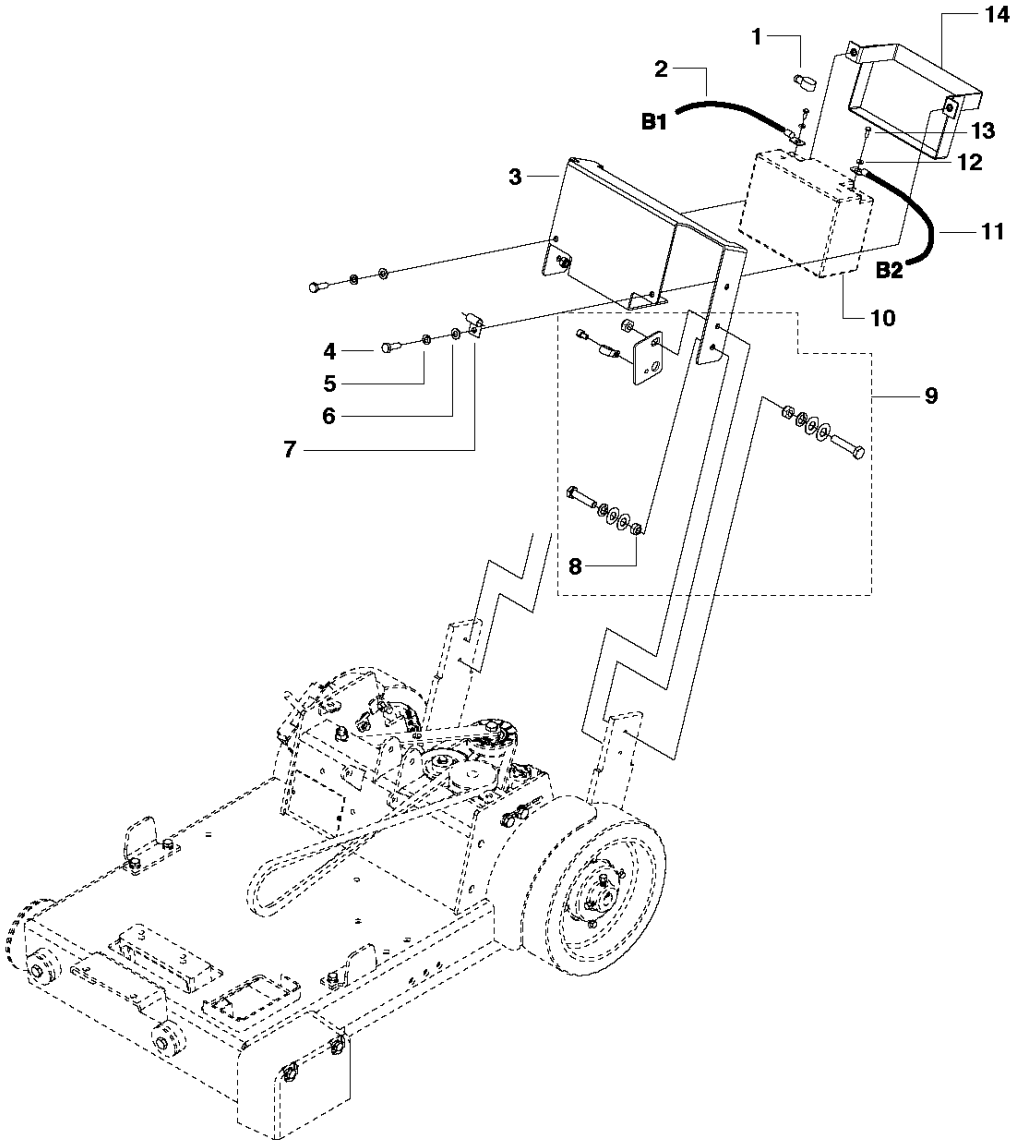

BATTERY & COVERS FS513/FS520/FS524, Valid for Machine numbers FS520-2150, FS524-1630 and forward, 2011-02

Ref	Part No	Description	Remark	QTY KIT
1	542 17 70-66	RUBBER BOOT. BATT. TERM./BLACK		2
2	542 18 22-54	CABLE		1
3	542 20 41-76	BRACE. TANK - PC HUSQ. ORANGE		1
4	725 24 53-71	SCREW EHHM		2
5	735 11 64-01	SPRING WASHER		2
6	734 11 63-01	WASHER		2
7	542 19 05-60	CLAMP. VINYL COATED .38 X .75		1
8	732 25 18-01	HEXAGON LOCKING NUT		5
9	585 69 43-01	FIXING PLATE		1
10	541 20 83-18	BATTERY. GEL CELL		1
11	542 18 22-53	CABLE. BATTERY. NEGATIVE		1
12	734 11 52-01	WASHER		2
13	725 23 66-71	SCREW EHHM		2
14	542 20 41-75	BRACE. BATTERY - PC H. ORANGE		1

Blade Guard - 18" FS513/FS520/FS524, Valid for Machine numbers FS520-2150, FS524-1630 and forward, 2011-02

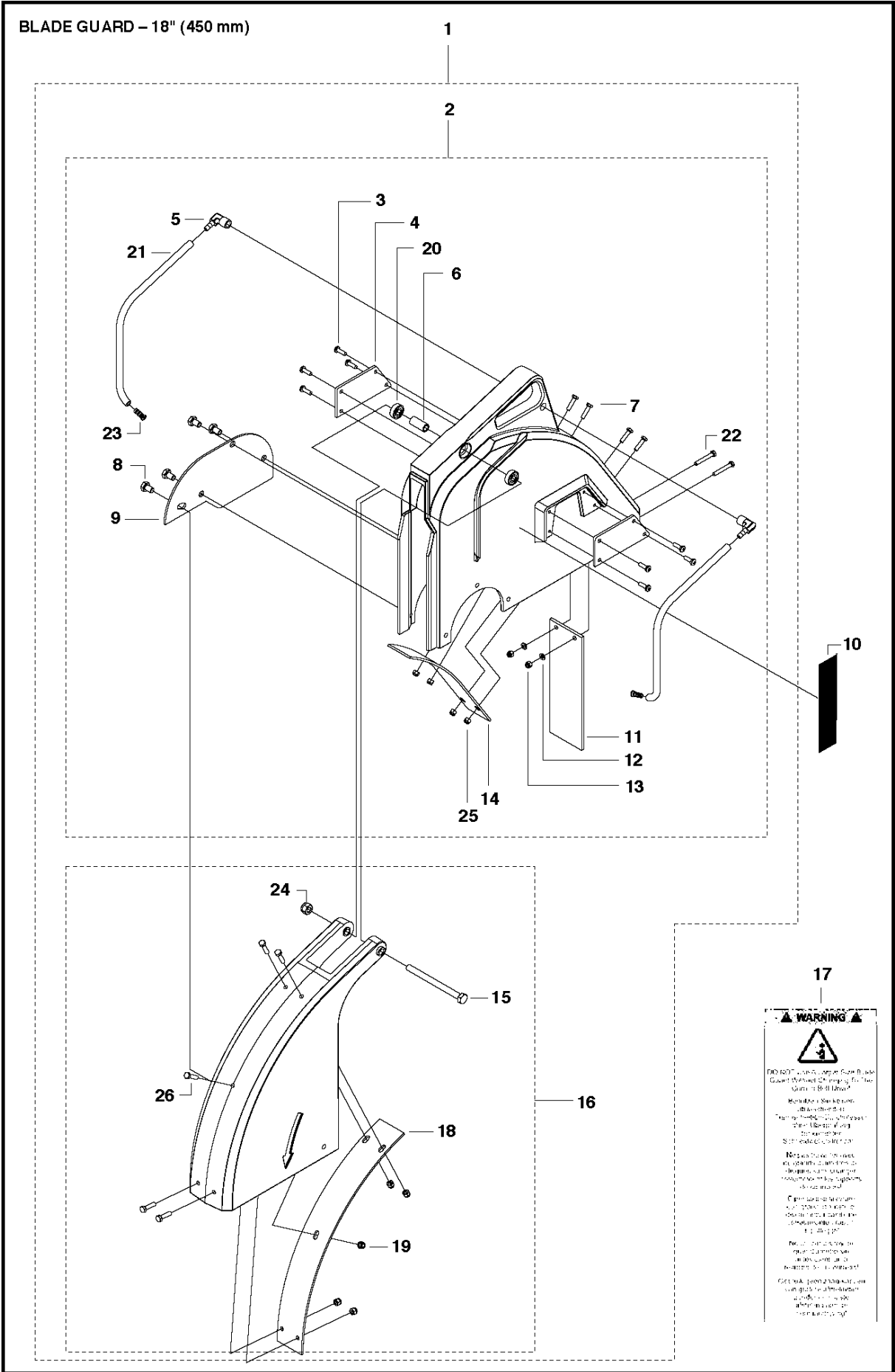

Blade Guard - 18" FS513/FS520/FS524, Valid for Machine numbers FS520-2150, FS524-1630 and forward, 2011-02

Ref	Part No	Description	Remark	QTY	KIT
1	542 20 23-60	BLADE GUARD		1	
2	542 20 23-62	ASSY. BLD GRD REAR - H. GREY		1	1
3	724 13 29-51	SCREW CRPANM		8	1, 2
4	541 20 82-45	PLATE.SPADE RETAINING.FINISHED		2	1, 2
5	541 20 82-63	ELBOW		2	1, 2
6	541 20 82-49	TUBE		1	1, 2
7	725 23 31-71	SCREW EHHM		4	1, 2
8	725 24 47-71	SCREW EHHM		4	1, 2
9	541 20 82-46	COVER		1	1, 2
10	542 16 72-98	AUFKLEBER		2	
11	542 20 40-64	SPLASH FLAP		1	1, 16
12	734 11 52-01	WASHER		2	1, 16
13	732 25 16-01	HEXAGON LOCKING NUT		2	1, 16
14	541 20 82-37	GUARD. STEEL. REAR. PC BLACK		1	1, 16
15	725 24 71-51	SCREW EHHM		1	1, 16
16	542 20 23-63	ASSY. BLD GRD FRONT - H. GREY		1	1, 16
17	542 16 72-98	AUFKLEBER		1	
18	541 20 82-40	GUARD. STEEL. FRONT. PC BLACK		1	1, 16
19	732 25 14-01	HEXAGON LOCKING NUT		5	1, 16
20	541 20 82-30	BALL BRG. 8MM ID		2	1, 2
21	541 20 82-65	TUBE		2	1, 2
22	725 23 76-71	SCREW EHHM		2	1, 2
23	542 20 40-63	SPRAY JET		2	1, 2
24	732 25 18-01	HEXAGON LOCKING NUT		1	1, 16
25	732 25 14-01	HEXAGON LOCKING NUT		4	1, 2
26	725 23 31-71	SCREW EHHM		5	1, 16

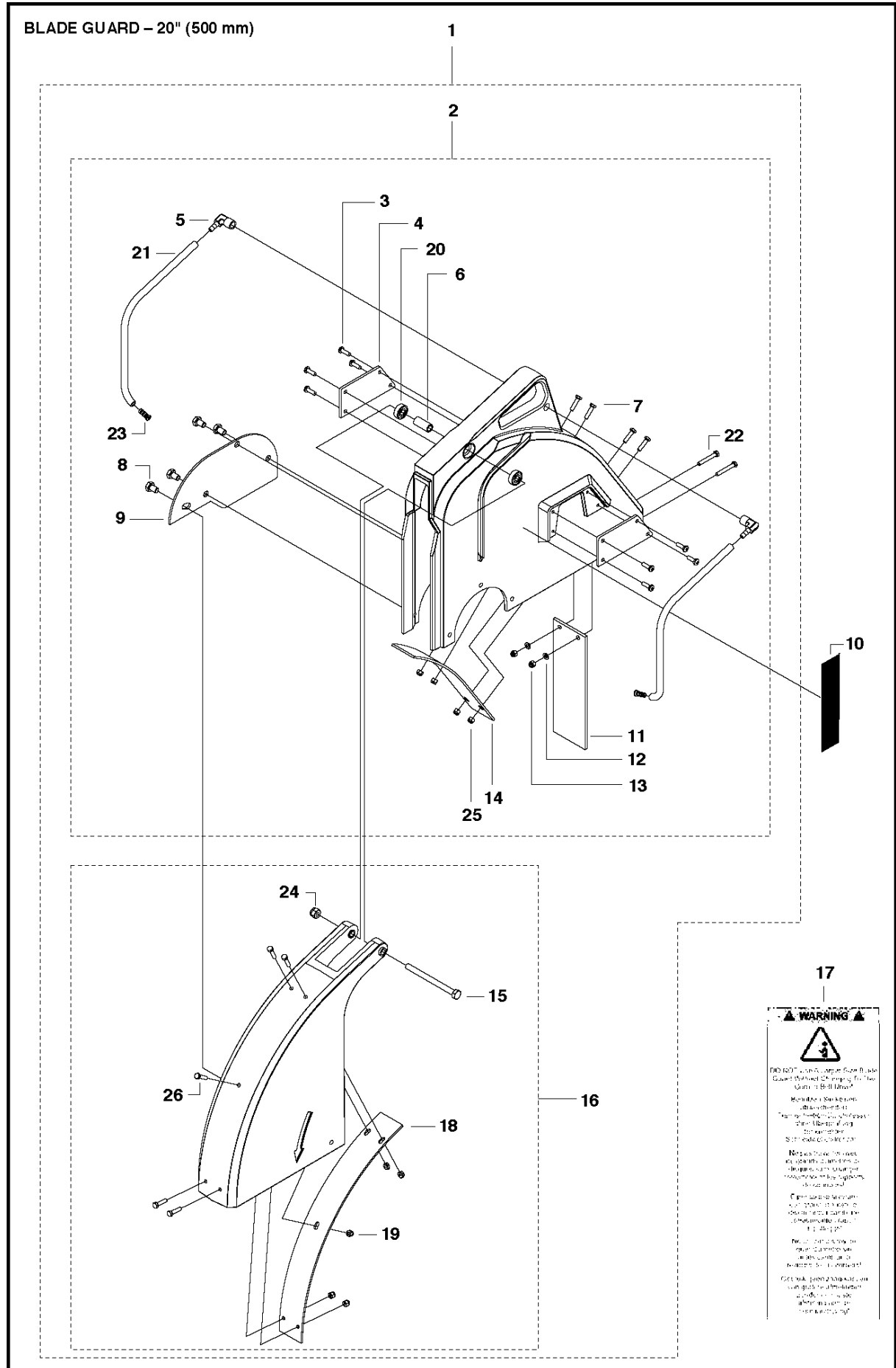

Blade Guard - 20" FS513/FS520/FS524, Valid for Machine numbers FS520-2150, FS524-1630 and forward, 2011-02

Ref	Part No	Description	Remark	QTY	KIT
1	542 20 40-89	BLADE GUARD		1	
2	542 20 41-44	ASSY. BLD GRD REAR		1	1
3	724 13 29-51	SCREW CRPANM		8	1, 2
4	541 20 82-45	PLATE.SPADE RETAINING.FINISHED		2	1, 2
5	541 20 82-63	ELBOW		2	1, 2
6	541 20 82-49	TUBE		1	1, 2
7	725 23 31-71	SCREW EHHM		4	1, 2
8	725 24 47-71	SCREW EHHM		4	1, 2
9	541 20 82-46	COVER		1	1, 2
10	542 16 72-98	AUFKLEBER		2	
11	542 20 40-64	SPLASH FLAP		1	1, 16
12	734 11 52-01	WASHER		2	1, 16
13	732 25 16-01	HEXAGON LOCKING NUT		2	1, 16
14	542 20 40-96	GUIDE BAR		1	1, 16
15	725 24 71-51	SCREW EHHM		1	1, 16
16	542 20 41-45	ASSY. BLD GRD FRONT		1	1, 16
17	542 16 72-98	AUFKLEBER		1	
18	542 20 40-97	GUIDE BAR		1	1, 16
19	732 25 14-01	HEXAGON LOCKING NUT		5	1, 16
20	541 20 82-30	BALL BRG. 8MM ID		2	1, 2
21	542 20 41-01	TUBE		2	1, 2
22	725 23 76-71	SCREW EHHM		2	1, 2
23	542 20 40-63	SPRAY JET		2	1, 2
24	732 25 18-01	HEXAGON LOCKING NUT		1	1, 16
25	732 25 14-01	HEXAGON LOCKING NUT		4	1, 2
26	725 23 31-71	SCREW EHHM		5	1, 16

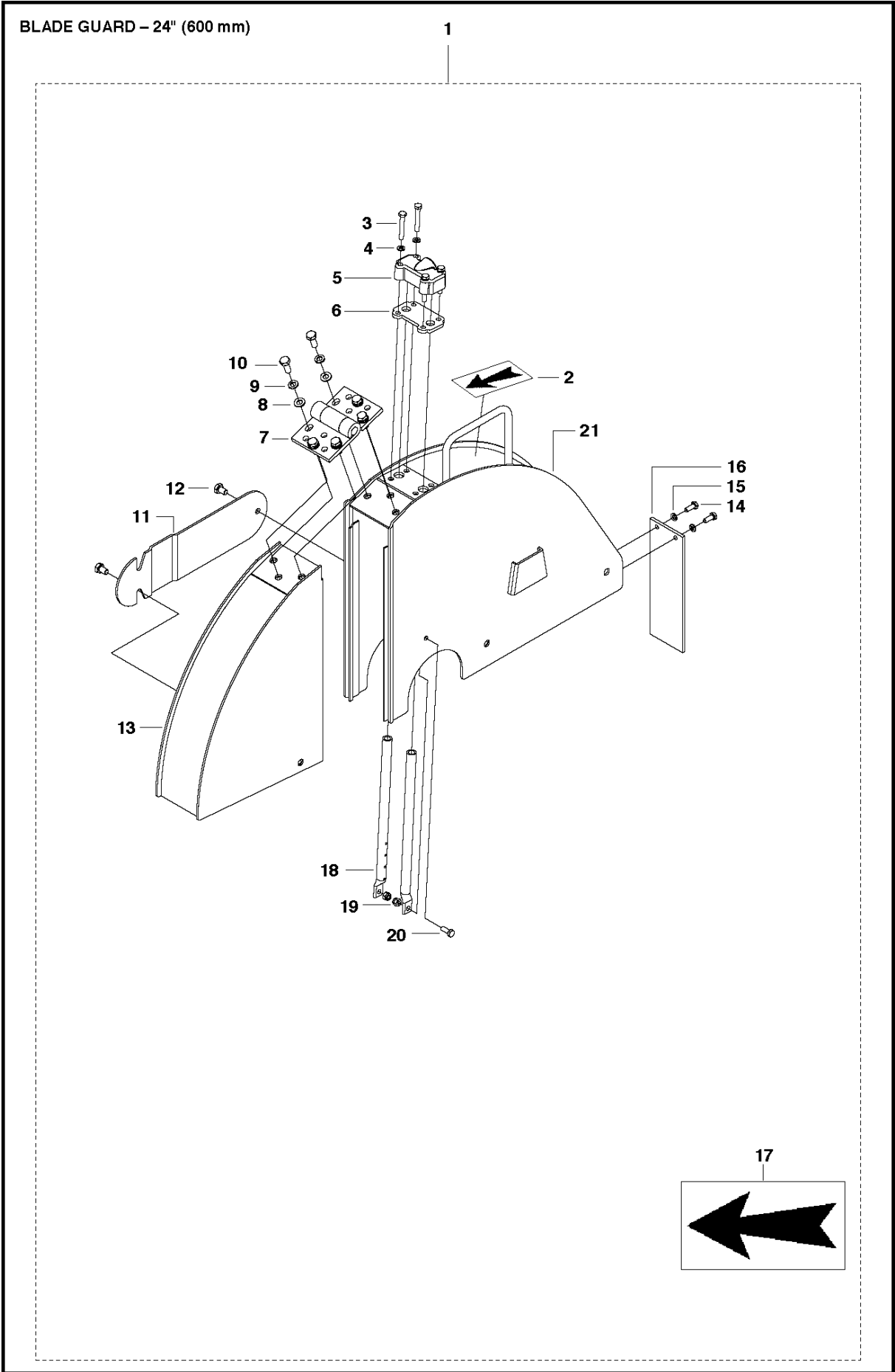

Blade Guard - 24" FS513/FS520/FS524, Valid for Machine numbers FS520-2150, FS524-1630 and forward, 2011-02

Ref	Part No	Description	Remark	QTY KIT
1	542 20 41-87	BLADE GUARD		1
2	543 85 00-37	STICKER		1
3	725 23 78-71	SCREW EHHM		4
4	735 11 53-01	WASHER		4
5	542 13 90-45	AXE		1
6	542 13 90-51	JOINT		1
7	542 19 05-19	HINGE		1
8	734 11 63-01	WASHER		6
9	735 11 64-01	SPRING WASHER		6
10	725 24 51-71	SCREW EHHM		6
11	542 20 42-04	COVER		1
12	725 24 47-71	SCREW EHHM		2
13	542 20 41-88	BLADEGRD. 24" FRONT PC H. GREY		1
14	725 23 68-71	SCREW EHHM		2
15	734 11 64-01	WASHER		2
16	542 20 40-64	SPLASH FLAP		1
17	543 85 00-37	STICKER		1
18	542 20 41-98	BLADEGUARD TUBE - GALVANIZED		2
19	732 25 16-01	HEXAGON LOCKING NUT		2
20	725 23 68-71	SCREW EHHM		2
21	542 20 41-92	BLADEGUARD. 24" REAR PC H GREY		1

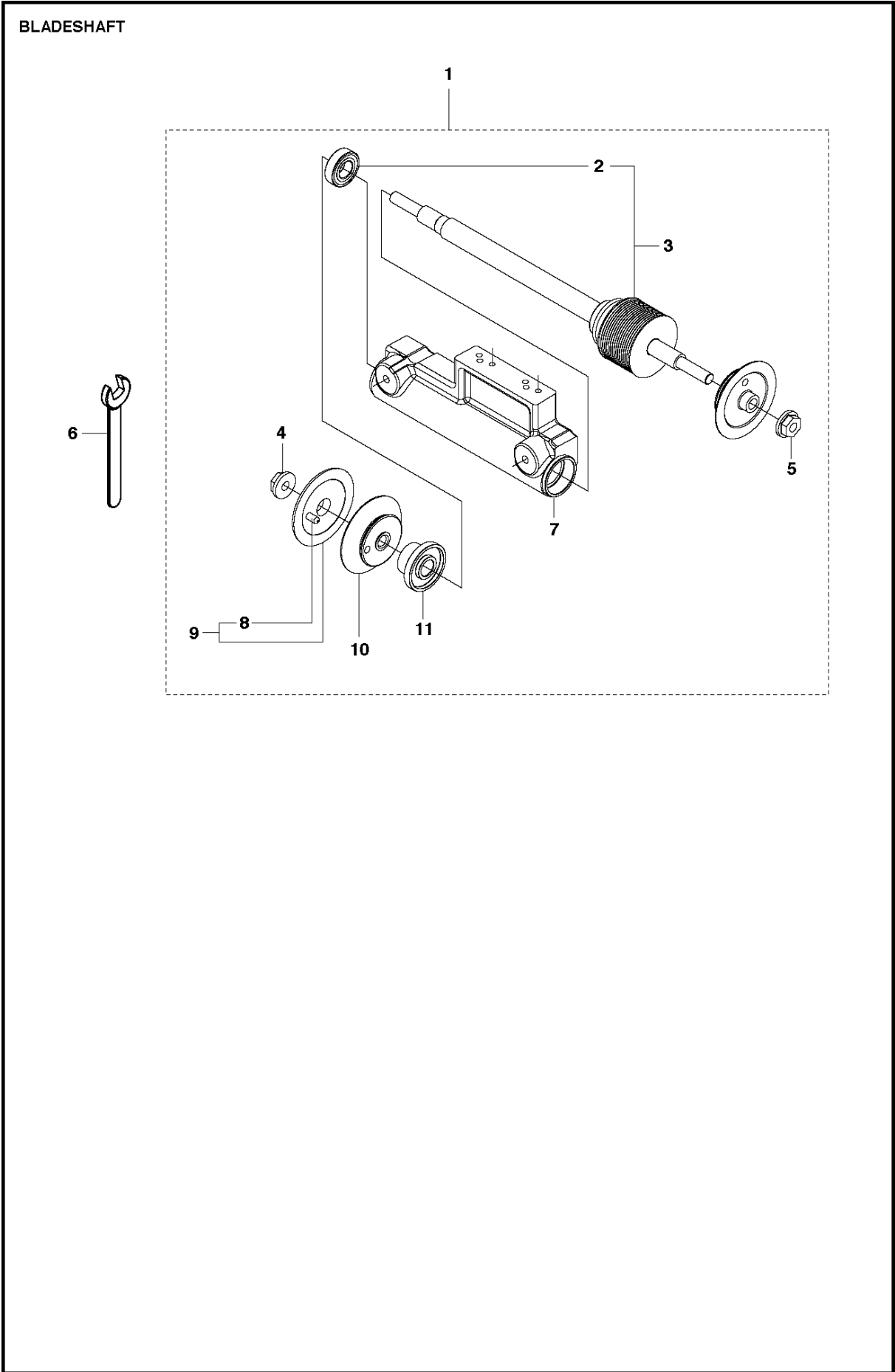

BLADESHAFT FS513/FS520/FS524, Valid for Machine numbers FS520-2150, FS524-1630 and forward, 2011-02

Ref	Part No	Description	Remark	QTY	KIT
1	541 20 72-41	BLADESHAFT ASSY		1	
2	541 20 81-60	BEARING		1	
3	504 00 79-01	BLADE SHAFT		1	1
4	542 16 78-46	NUT		1	1
5	542 16 78-47	NUT		1	1
6	542 20 22-92	WRENCH		1	
7	541 20 72-40	BLADESHAFT TUBE MACHINING		1	1
8	542 16 79-64	PION US/		1	1
9	542 16 79-62	COLLAR		1	1
10	542 16 71-85	COLLAR		2	1
11	541 20 71-88	SLINGER. BLACK OXIDE		1	1

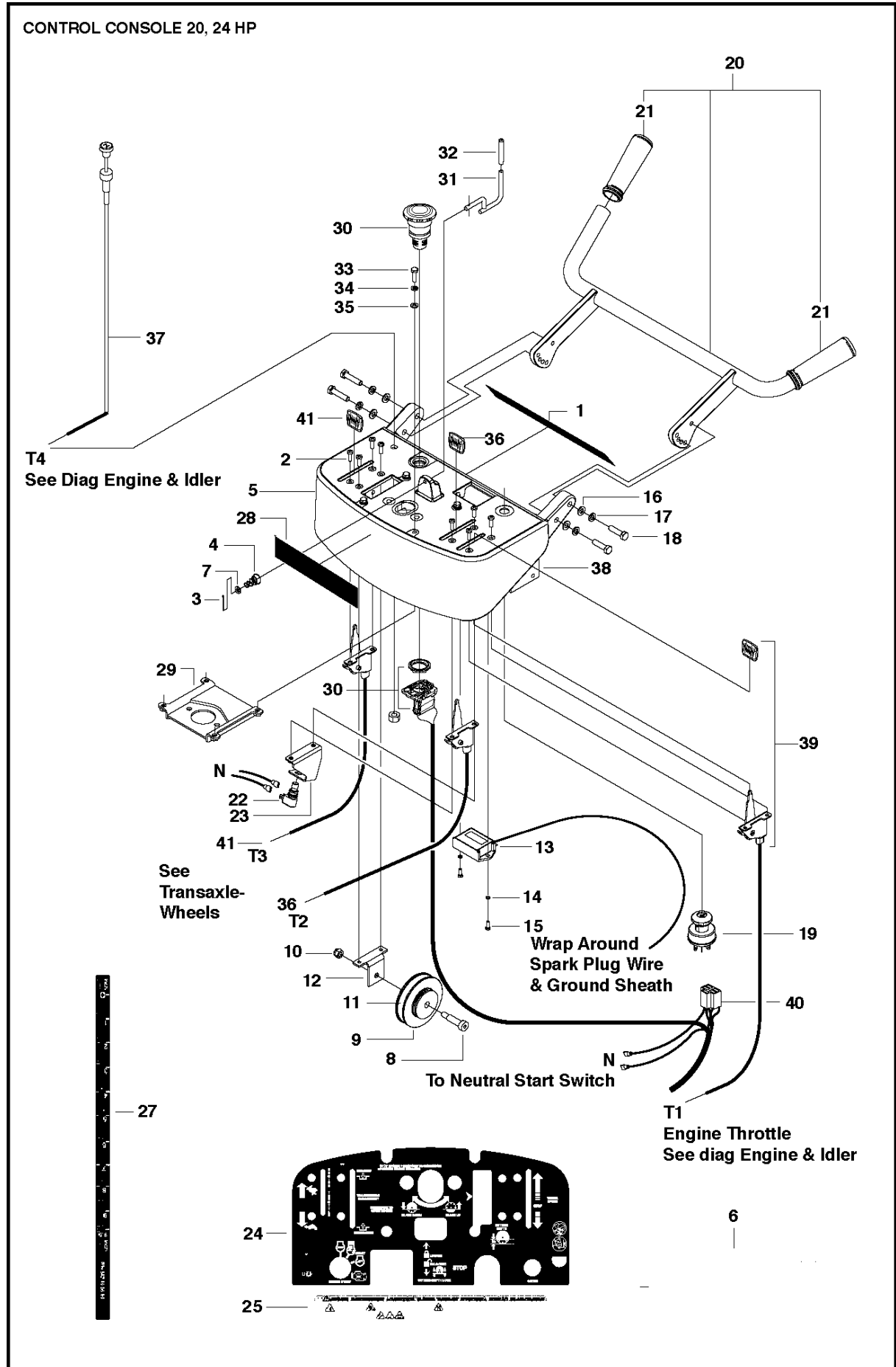

CONTROL CONSOLE FS513/FS520/FS524, Valid for Machine numbers FS520-2150, FS524-1630 and forward, 2011-02

Ref	Part No	Description	Remark	QTY KIT
1	542 19 06-38	DECAL		1
2	724 13 29-51	SCREW CRPANM		8
3	721 61 43-01	PIN. COTTER 1.6X22 ISO 1234		1
4	542 20 41-13	SPRING		1
5	586 46 90-01	CONSOLE		1
6	542 19 07-33	DECAL		1
7	734 11 52-01	WASHER		1
8	541 20 82-79	HSHS M10 X 30		1
9	542 20 21-63	WHEEL. DEPTH GAUGE		1
10	732 25 18-71	HEXAGON LOCKING NUT		1
11	542 19 05-89	DECAL		1
12	542 20 21-64	BRACKET. DEPTH GAUGE. Z/P		1
13	539 30 05-56	TINY TACH/HOURMETER		1
14	735 11 36-01	SPRING WASHER 4.1X7.1		2
15	725 22 91-71	SCREW EHHM		2
16	734 11 63-01	WASHER		4
17	735 11 64-01	SPRING WASHER		4
18	725 24 57-71	SCREW EHHM		4
19	542 17 79-20	KEY SWITCH		1
20	542 20 41-86	HANDLE BAR		1
21	542 13 95-68	FS902T GRIP/		2
22	542 20 40-52	SWITCH		1
23	504 06 80-04	BRACKET		1
24	502 24 01-03	DECAL		1
25	542 19 06-38	DECAL		1
27	542 19 05-89	DECAL		1
28	542 19 07-33	DECAL		1
29	502 85 62-05	BRACKET		1
30	582 10 16-01	STOP SWITCH		1
31	542 20 41-09	LOCKING PIN		1
32	542 20 21-69	CAP. ROUND VINYL		1
33	725 23 70-71	SCREW EHHM		4
34	735 11 53-01	WASHER		4
35	734 11 52-01	WASHER		4
36	542 20 23-30	CABLE ASSY		2
37	577 75 48-01	CHOKE		1
38	542 19 06-36	**502240103**		1
39	587 69 69-01	CABLE		1
40	586 07 94-01	HARNESS		1
41	581 49 13-01	CABLE KIT		1

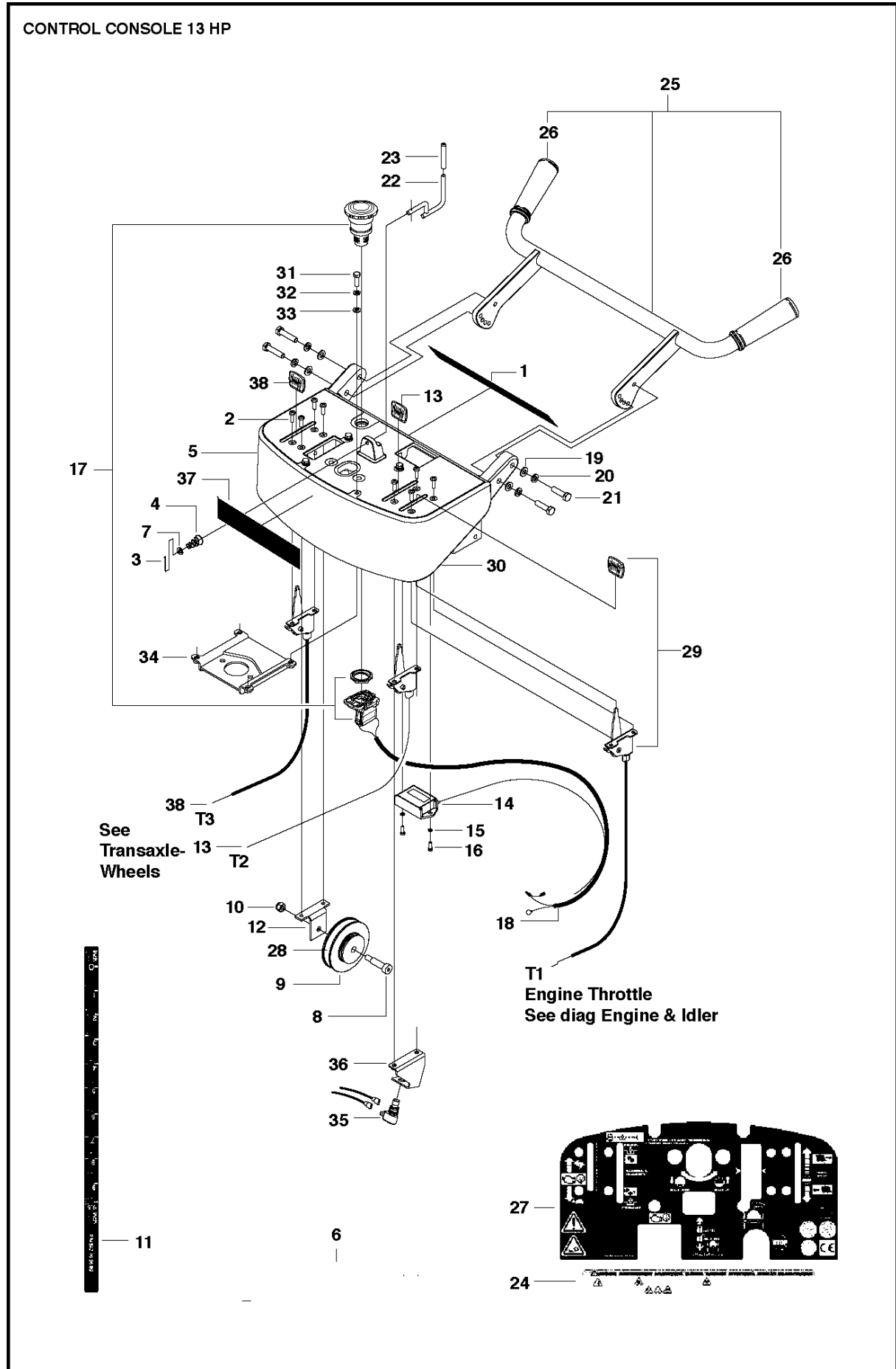

CONTROL CONSOLE FS513/FS520/FS524, Valid for Machine numbers FS520-2150, FS524-1630 and forward, 2011-02

Ref	Part No	Description	Remark	QTY KIT
1	542 19 06-38	DECAL		1
2	724 13 29-51	SCREW CRPANM		8
3	721 61 43-01	PIN. COTTER 1.6X22 ISO 1234		1
4	542 20 41-13	SPRING		1
5	586 46 90-01	CONSOLE		1
6	542 19 07-33	DECAL		1
7	734 11 52-01	WASHER		1
8	541 20 82-79	HSHS M10 X 30		1
9	542 20 21-63	WHEEL. DEPTH GAUGE		1
10	732 25 18-71	HEXAGON LOCKING NUT		1
11	542 19 05-89	DECAL		1
12	542 20 21-64	BRACKET. DEPTH GAUGE. Z/P		1
13	542 20 23-30	CABLE ASSY		2
14	539 30 05-56	TINY TACH/HOURMETER		1
15	735 11 36-01	SPRING WASHER 4.1X7.1		2
16	725 22 91-71	SCREW EHHM		2
17	582 10 15-01	STOP SWITCH		1
18	542 18 22-52	CORD		1
19	734 11 63-01	WASHER		4
20	735 11 64-01	SPRING WASHER		4
21	725 24 57-71	SCREW EHHM		4
22	542 20 41-09	LOCKING PIN		1
23	542 20 21-69	CAP. ROUND VINYL		1
24	542 19 06-38	DECAL		1
25	542 20 41-86	HANDLE BAR		1
26	542 13 95-68	FS902T GRIP/		2
27	502 24 01-01	DECAL		1
28	542 19 05-89	DECAL		1
29	542 20 41-51	CABLE. THROTTLE FS513		1
30	502 24 01-01	DECAL		1
31	725 23 70-71	SCREW EHHM		4
32	735 11 53-01	WASHER		4
33	734 11 52-01	WASHER		4
34	502 85 62-05	BRACKET		1
35	542 20 40-52	SWITCH		1
36	504 06 80-04	BRACKET		1
37	542 19 07-33	DECAL		1
38	581 49 13-01	CABLE KIT		1

COVERS

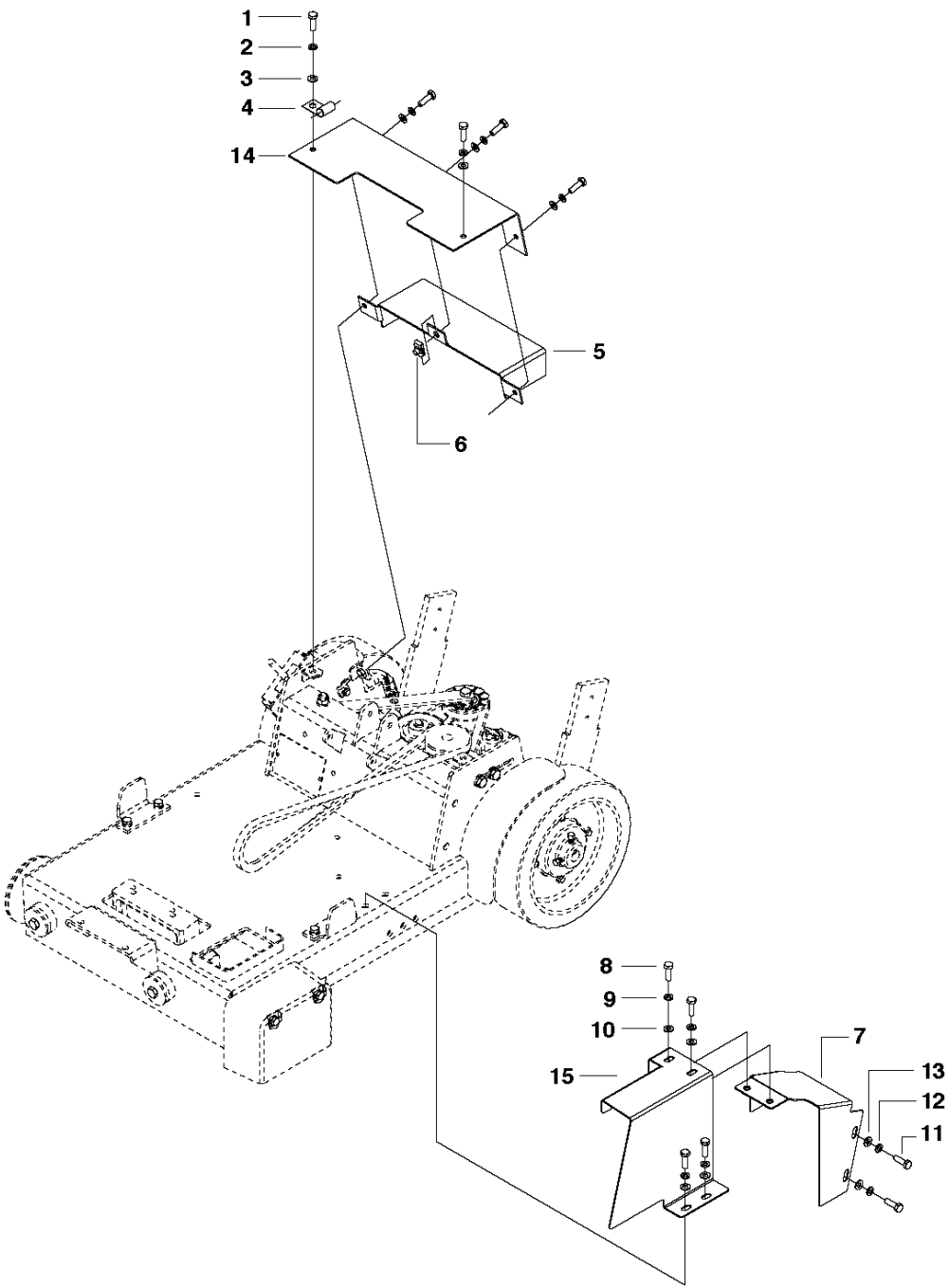

COVER FS513/FS520/FS524, Valid for Machine numbers FS520-2150, FS524-1630 and forward,
2011-02

Ref	Part No	Description	Remark	QTY KIT
1	725 24 53-71	SCREW EHHM		5
2	735 11 64-01	SPRING WASHER		5
3	734 11 63-01	WASHER		5
4	542 16 69-55	CLAMP. VINYL COATED 3/8 X 1.0		1
5	542 20 41-72	COVER		1
6	542 20 20-99	U-NUT. M8X1.25(1.5-5.5MM MATL)		1
7	542 20 41-71	SIDE COVER. BACK. PC H ORANGE		1
8	725 24 53-71	SCREW EHHM		4
9	735 11 64-01	SPRING WASHER		4
10	734 11 63-01	WASHER		4
11	725 24 53-71	SCREW EHHM		4
12	735 11 64-01	SPRING WASHER		2
13	734 11 63-01	WASHER		2
14	542 20 41-73	COVER		1
15	577 66 89-01	BELT COVER		1

ENGINE & IDLER 13 HP

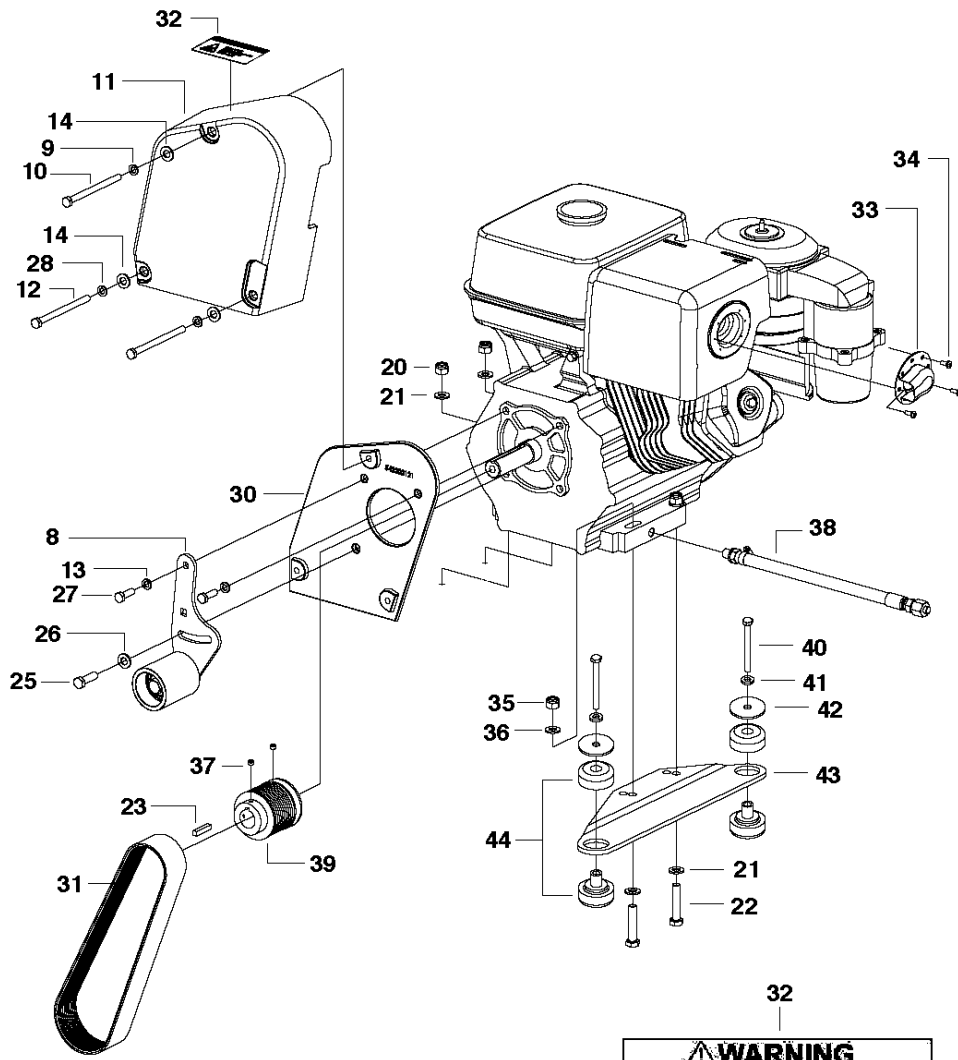

WARNING

Muffler Is HOT!
May Cause Burns And / Or
Ignition Of Material
Avoid Contact!

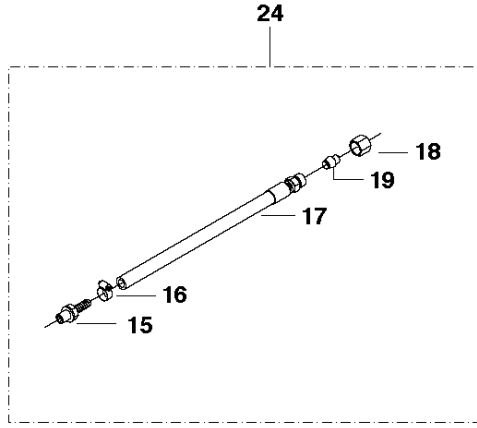
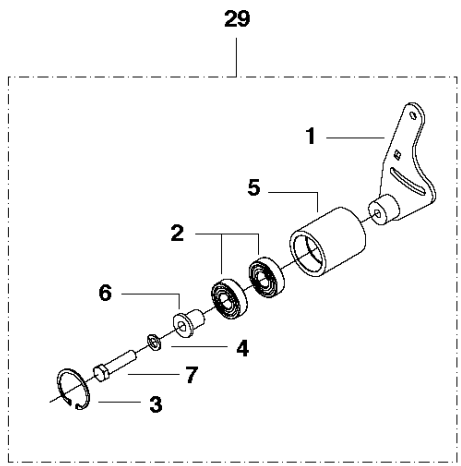

ENGINE & IDLER FS513/FS520/FS524, Valid for Machine numbers FS520-2150, FS524-1630 and forward, 2011-02

Ref	Part No	Description	Remark	QTY	KIT
1	541 20 81-90	PLATE. TENSIONING. BLACK		1	29
2	542 13 92-73	BALL BEARING		2	29
3	735 31 40-10	CIRCLIP		1	29
4	735 11 78-01	BEILAGSCHEIBE		1	29
5	541 20 81-95	IDLER SHEAVE		1	29
6	541 20 81-94	SPACER		1	29
7	725 25 42-51	SCREW EHHM		1	29
8	541 20 81-96	IDLER SHEAVE ASSEMBLY		1	
9	735 11 64-01	SPRING WASHER		1	
10	725 24 71-71	HHCS M8 X 1.25 X 100 GR8.8		1	
11	542 20 21-22	BELT GUARD		1	
12	725 24 73-51	SCREW EHHM		2	
13	735 11 64-01	SPRING WASHER		2	
14	734 11 63-01	WASHER		2	
15	542 16 71-33	ADAPTER. M12 X 10MM HOSE BARB		1	24
16	539 30 00-72	CLAMP, HOSE, MAH-4 FUEL LINE		1	24
17	542 20 21-52	HOSE ASSY		1	24
18	542 16 76-22	NUT		1	24
19	542 16 73-06	CAP. BLANKING (OIL DRAIN) Z/P		1	24
20	732 25 20-01	HEXAGON LOCKING NUT		2	
21	734 11 72-01	WASHER		2	
22	725 25 01-51	SCREW EHHM		2	
23	539 91 27-57	KEY		1	
24	542 20 21-51	OIL DRAIN ASSY		1	
25	539 97 69-41	SCREW		1	
26	543 04 47-32	RONDEL RESSOR 23X10,2X1/		1	
27	541 20 51-97	BOLT		2	
28	735 11 64-01	SPRING WASHER		2	
29	541 20 81-96	IDLER SHEAVE ASSEMBLY		1	
30	542 20 41-80	BELT GRD PLATE TRIM-PC H.GREY		1	
31	542 20 21-50	STRAP		1	
32	542 16 90-65	DECAL		1	
33	543 04 78-41	BOUCHON ECHAPPEMENT/UNIVERSEL		1	
34	541 20 09-86	DEFLECTOR		3	
35	732 25 20-01	HEXAGON LOCKING NUT		2	
36	734 11 72-01	WASHER		2	
37	542 13 97-68	SHSS. M8 X 6 DIN 916 GR12.9		4	
38	542 20 21-51	OIL DRAIN ASSY		1	
39	542 20 22-38	SHEAVE PK.67MM.25.4MM.12G.B/O		1	
40	725 25 05-51	SCREW EHHM		2	
41	735 11 73-01	SPRING WASHER		2	
42	542 20 21-06	WASHER		2	
43	542 20 41-79	PLATE. ENGINE MOUNT PC H. GREY		1	
44	542 16 11-96	ISOLATOR		2	

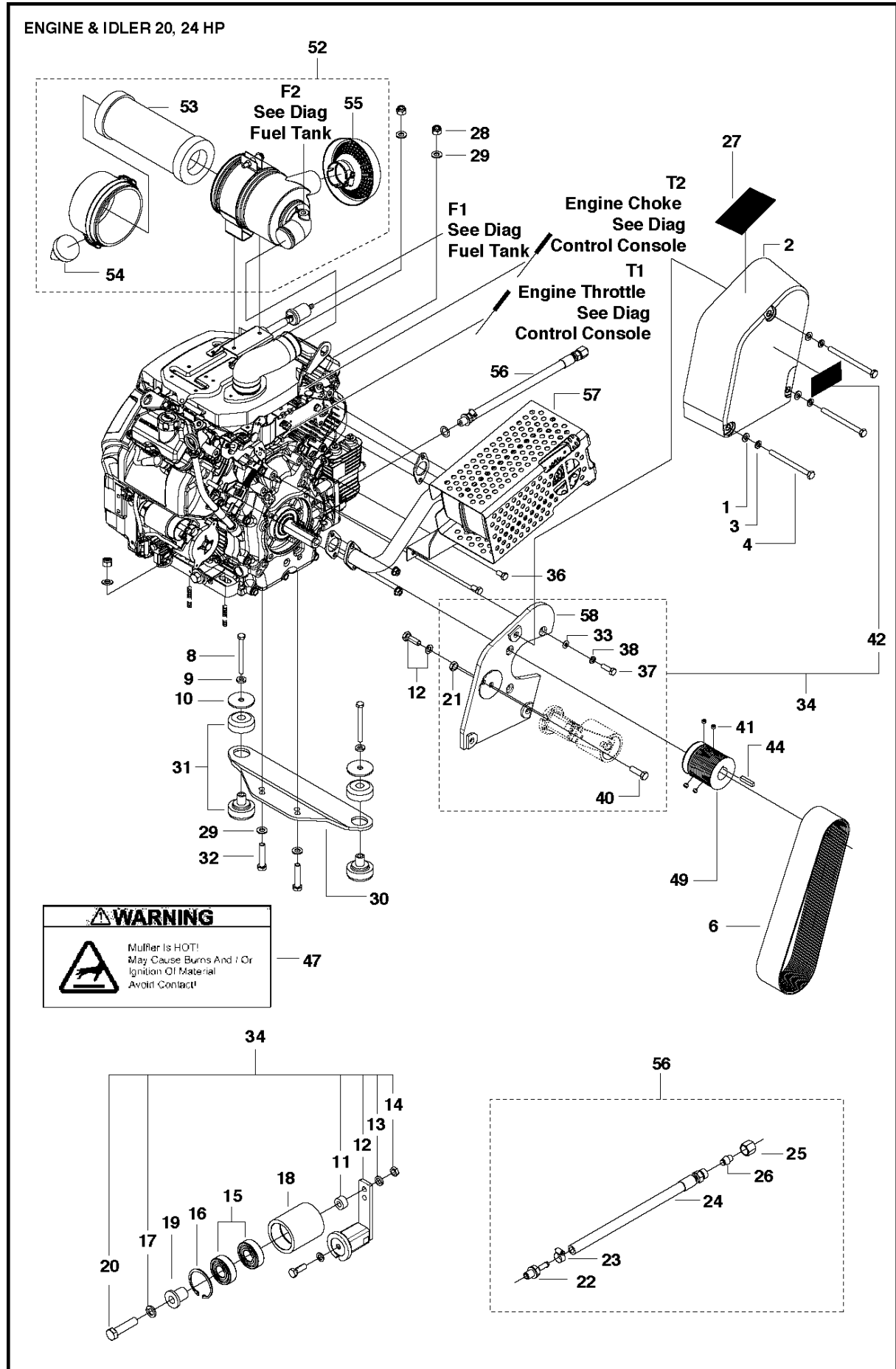

ENGINE & IDLER FS513/FS520/FS524, Valid for Machine numbers FS520-2150, FS524-1630 and forward, 2011-02

Ref	Part No	Description	Remark	QTY	KIT
1	734 11 63-01	WASHER		3	
2	542 20 21-22	BELT GUARD		1	
3	735 11 64-01	SPRING WASHER		3	
4	725 24 73-51	SCREW EHHM		3	
6	504 06 83-01	BELT		1	
8	725 25 05-51	SCREW EHHM		2	
9	735 11 73-01	SPRING WASHER		2	
10	542 20 21-06	WASHER		2	
11	586 09 11-01	SPACER		1	
12	586 19 59-01	BELT TENSIONER		1	
13	735 11 78-01	BEILAGSCHEIBE		1	
14	731 43 22-01	HEXAGON THIN NUT		1	34
15	542 13 92-73	BALL BEARING		2	34
16	735 31 40-10	CIRCLIP		1	34
17	734 11 78-01	WASHER		1	34
18	541 20 81-95	IDLER SHEAVE		1	34
19	541 20 81-94	SPACER		1	34
20	725 25 46-51	SCREW EHHM		1	34
21	732 25 18-01	HEXAGON LOCKING NUT		1	34
22	577 66 83-01	ADAPTER		1	56
23	539 30 00-72	CLAMP, HOSE, MAH-4 FUEL LINE		1	56
24	542 20 21-52	HOSE ASSY		1	56
25	542 16 76-22	NUT		1	56
26	542 16 73-06	CAP. BLANKING (OIL DRAIN) Z/P		1	56
27	542 16 90-65	DECAL		1	
28	732 25 20-01	HEXAGON LOCKING NUT		4	
29	734 11 72-01	WASHER		4	
30	542 20 41-79	PLATE. ENGINE MOUNT PC H. GREY		1	
31	542 16 11-96	ISOLATOR		2	
32	725 25 01-51	SCREW EHHM		2	
33	734 11 63-01	WASHER		3	
34	586 30 82-01	BELT		1	
36	725 24 49-71	SCREW EHHM		2	
37	541 20 51-97	BOLT		3	
38	735 11 64-01	SPRING WASHER		3	
40	725 54 57-01	SCREW IHSCM		1	
41	542 13 97-68	SHSS. M8 X 6 DIN 916 GR12.9		4	
42	586 23 93-01	DECAL		1	
44	539 91 27-57	KEY		1	
47	542 16 90-65	DECAL		1	
49	504 73 65-02	PULLEY		1	
52	577 80 27-01	AIR CLEANER		1	
53	577 99 87-01	ELEMENT		1	52
54	577 99 90-01	VALVE		1	52
55	577 99 89-01	HUB CAP		1	52
56	577 66 84-01	ASSEMBLY		1	
57	577 60 06-04	MUFFLER		1	
58	586 09 15-02	PLATE		1	

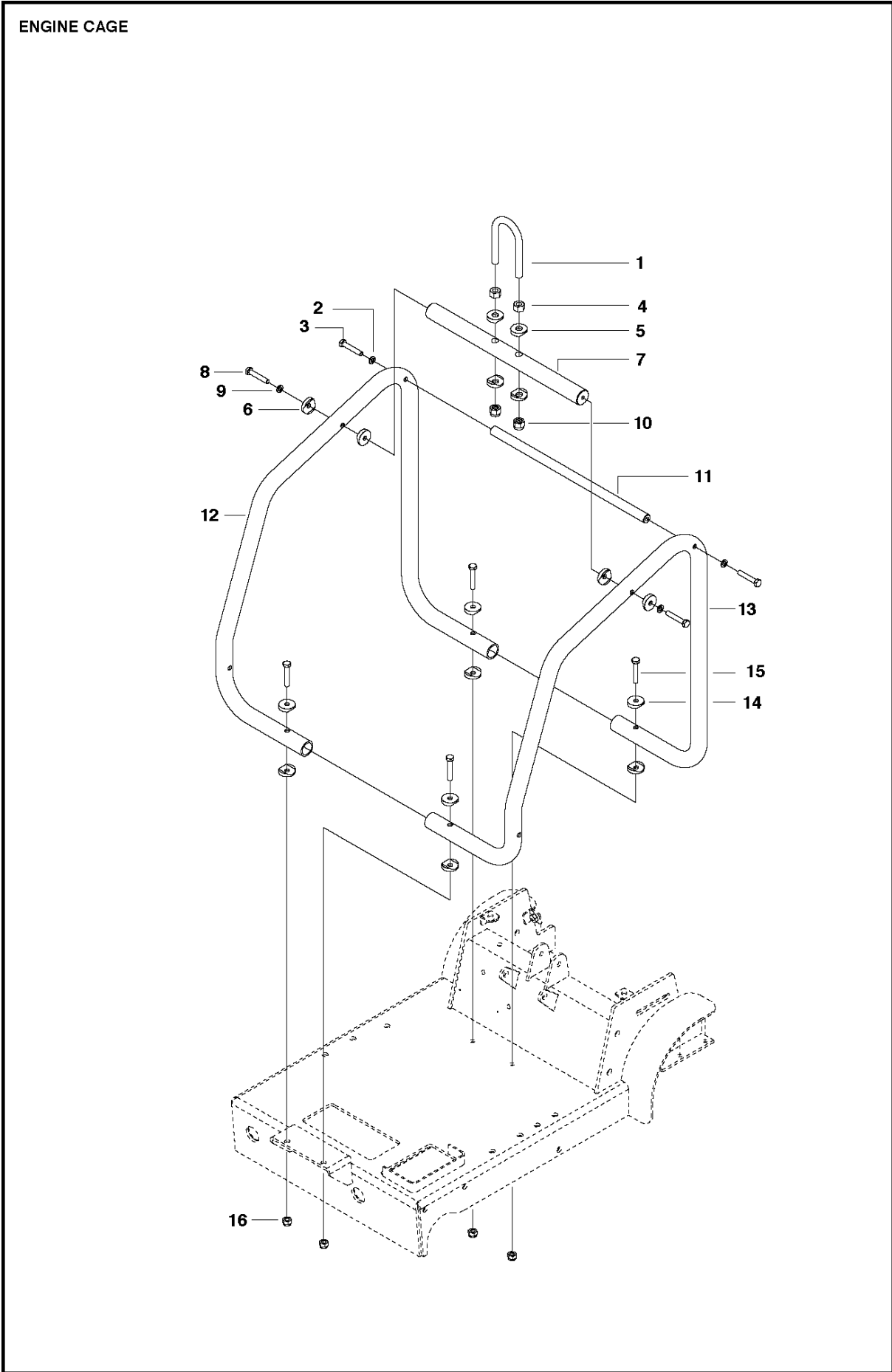

ENGINE CAGE FS513/FS520/FS524, Valid for Machine numbers FS520-2150, FS524-1630 and forward, 2011-02

Ref	Part No	Description	Remark	QTY KIT
1	542 20 21-87	U-BOLT. Z/P		1
2	735 11 64-01	SPRING WASHER		2
3	725 24 61-71	SCREW EHHM		2
4	731 23 22-01	HEXAGON NUT		2
5	542 20 21-88	WASHER		4
6	542 20 21-84	WASHER		4
7	542 20 21-86	BAR. LIFTING BAIL. FINISHED		1
8	725 24 61-71	SCREW EHHM		2
9	735 11 64-01	SPRING WASHER		2
10	732 25 22-01	HEXAGON LOCKING NUT		2
11	542 20 21-85	BAR. TANK PIVOT. FINISHED		1
12	542 20 21-81	ENGINE CAGE. RIGHT. FINISHED	FS513	1
12	577 66 86-01	ENGINE CAGE	FS520, FS524	1
13	542 20 21-82	ENGINE CAGE. LEFT. FINISHED	FS513	1
13	577 66 85-01	ENGINE CAGE	FS520, FS524	1
14	542 20 21-84	WASHER		8
15	725 24 63-51	SCREW EHHM		4
16	732 25 18-01	HEXAGON LOCKING NUT		1

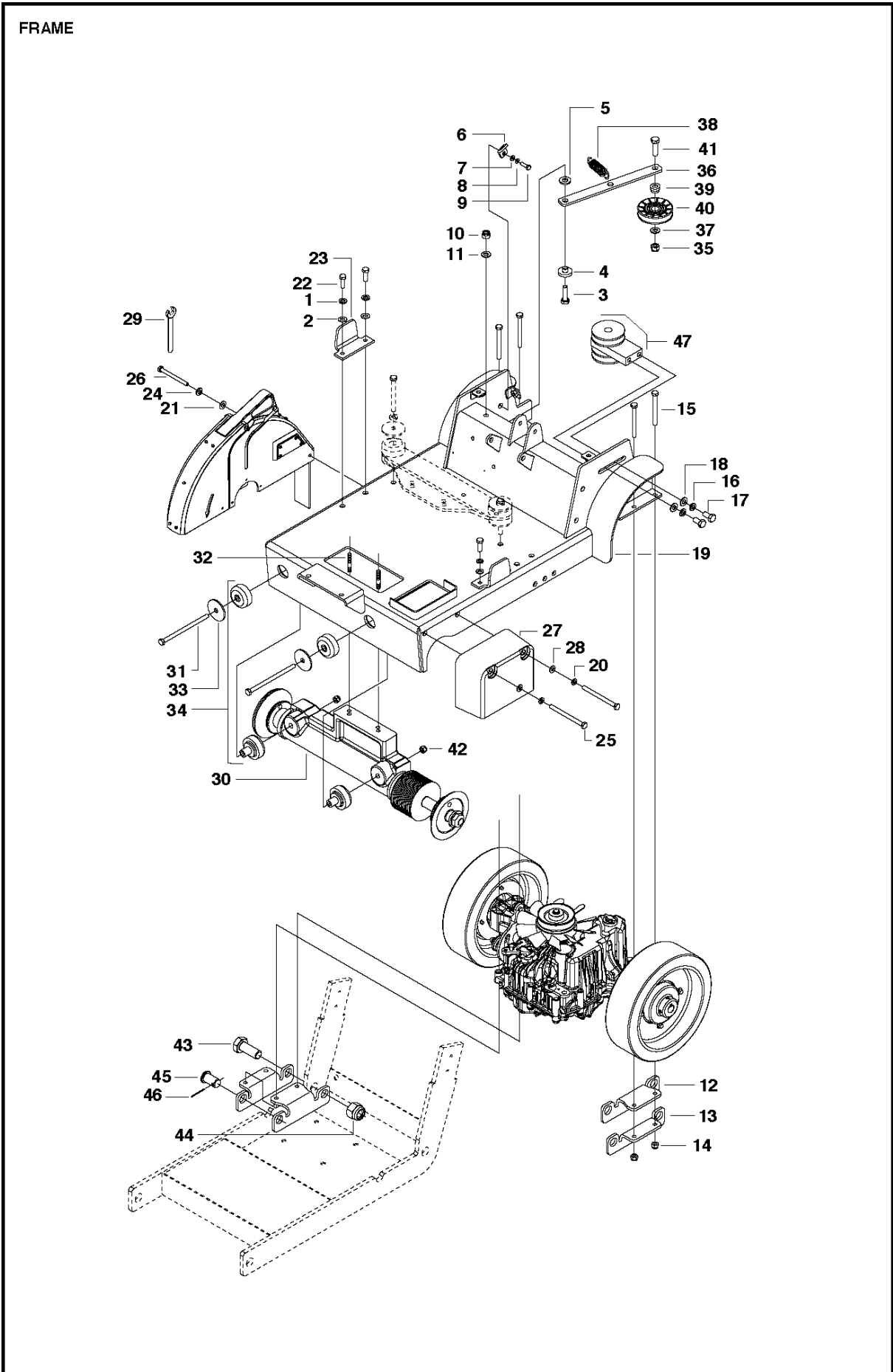

FRAME FS513/FS520/FS524, Valid for Machine numbers FS520-2150, FS524-1630 and forward, 2011-02

Ref	Part No	Description	Remark	QTY KIT
1	735 11 64-01	SPRING WASHER		4
2	734 11 63-01	WASHER		4
3	725 24 95-71	SCREW EHHM		1
4	504 11 10-02	BUSHING		1
5	504 11 13-02	SPACER		1
6	542 20 31-17	SPRING ANCHOR. Z/P		1
7	734 11 52-01	WASHER		1
8	735 11 53-01	WASHER		1
9	725 23 70-71	SCREW EHHM		1
10	732 25 20-01	HEXAGON LOCKING NUT		1
11	734 11 72-01	WASHER		1
12	541 20 72-12	BRACKET		2
13	541 20 72-14	BRACKET		2
14	732 25 18-01	HEXAGON LOCKING NUT		4
15	725 24 67-51	SCREW EHHM		4
16	735 11 73-01	SPRING WASHER		2
17	725 24 91-71	SCREW EHHM		2
18	734 11 72-01	WASHER		2
19	542 20 41-40	BASE WELDMENT HUSQ. ORANGE		1
20	735 11 64-01	SPRING WASHER		1
21	734 11 63-01	WASHER		1
22	725 24 53-71	SCREW EHHM		4
23	542 20 41-85	SPADE. BLADE GUARD PC H. GREY		2
24	735 11 64-01	SPRING WASHER		2
25	725 24 71-51	SCREW EHHM		2
26	725 24 71-71	HHCS M8 X 1.25 X 100 GR8.8		1
27	542 20 23-74	SHAFT GUARD- PC H. GREY		1
28	734 11 63-01	WASHER		2
29	543 04 58-91	CLE FOURCH DIN894/13CHRO/		1
30	541 20 72-41	BLADESHAFT ASSY		1
31	542 18 44-55	HHCS. M10X1.5X130MM Z/P		2
32	542 20 22-89	STUD. M10 X 1.5 X 52MM LONG		2
33	542 20 21-06	WASHER		2
34	542 16 11-96	ISOLATOR		2
35	732 25 20-01	HEXAGON LOCKING NUT		2
36	541 20 72-29	BAR. IDLER. BLACK		1
37	734 11 72-01	WASHER		1
38	542 20 23-33	SPRING. TENSIONING		1
39	542 20 41-37	BUSHING		1
40	542 16 77-63	PULLEY		1
41	725 24 99-71	SCREW EHHM		1
42	732 25 20-01	HEXAGON LOCKING NUT		1
43	542 20 41-35	HHCS. M20X2.5 X 50MM LG G10.9		2
44	543 07 40-65	NUT		2
45	542 20 41-21	PIN. CLEVIS 20MM X 34MM. Z/P		2
46	721 62 14-01	SPLIT PIN		2
47	541 20 83-19	JACKSHAFT ASSEMBLY		1

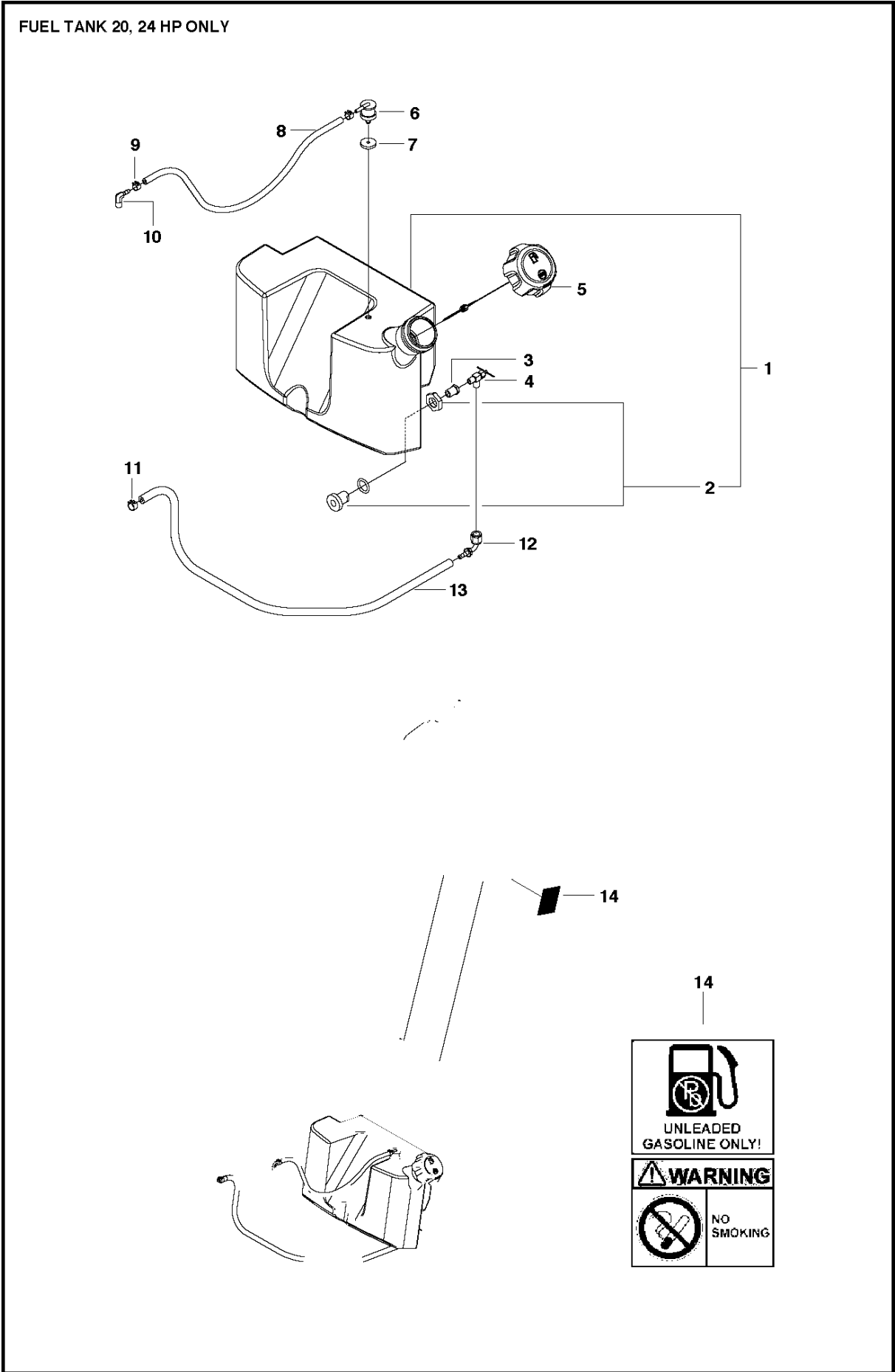

FUEL TANK FS513/FS520/FS524, Valid for Machine numbers FS520-2150, FS524-1630 and forward, 2011-02

Ref	Part No	Description	Remark	QTY	KIT
1	585 19 91-01	FUEL TANK ASSY		1	
2	585 18 78-01	FITTING		1	1
3	542 19 03-93	BUSHING		1	
4	542 19 03-92	VALVE. FUEL. .25SAE X .13MNPT		1	
5	586 02 73-01	CAP		1	
6	576 61 81-01	VALVE		1	
7	584 95 21-01	GROMMET		1	
8	578 07 72-01	HOSE		1	
9	577 81 35-02	CLAMP		2	
10	574 60 95-03	FITTING		1	
11	577 81 35-01	CLAMP		1	
12	506 95 69-01	FITTING		1	
13	578 07 73-01	HOSE		1	
14	542 19 06-39	DECAL		1	

HEIGHT ADJUSTMENT FS513/FS520/FS524, Valid for Machine numbers FS520-2150, FS524-1630 and forward, 2011-02

SCREW FEED

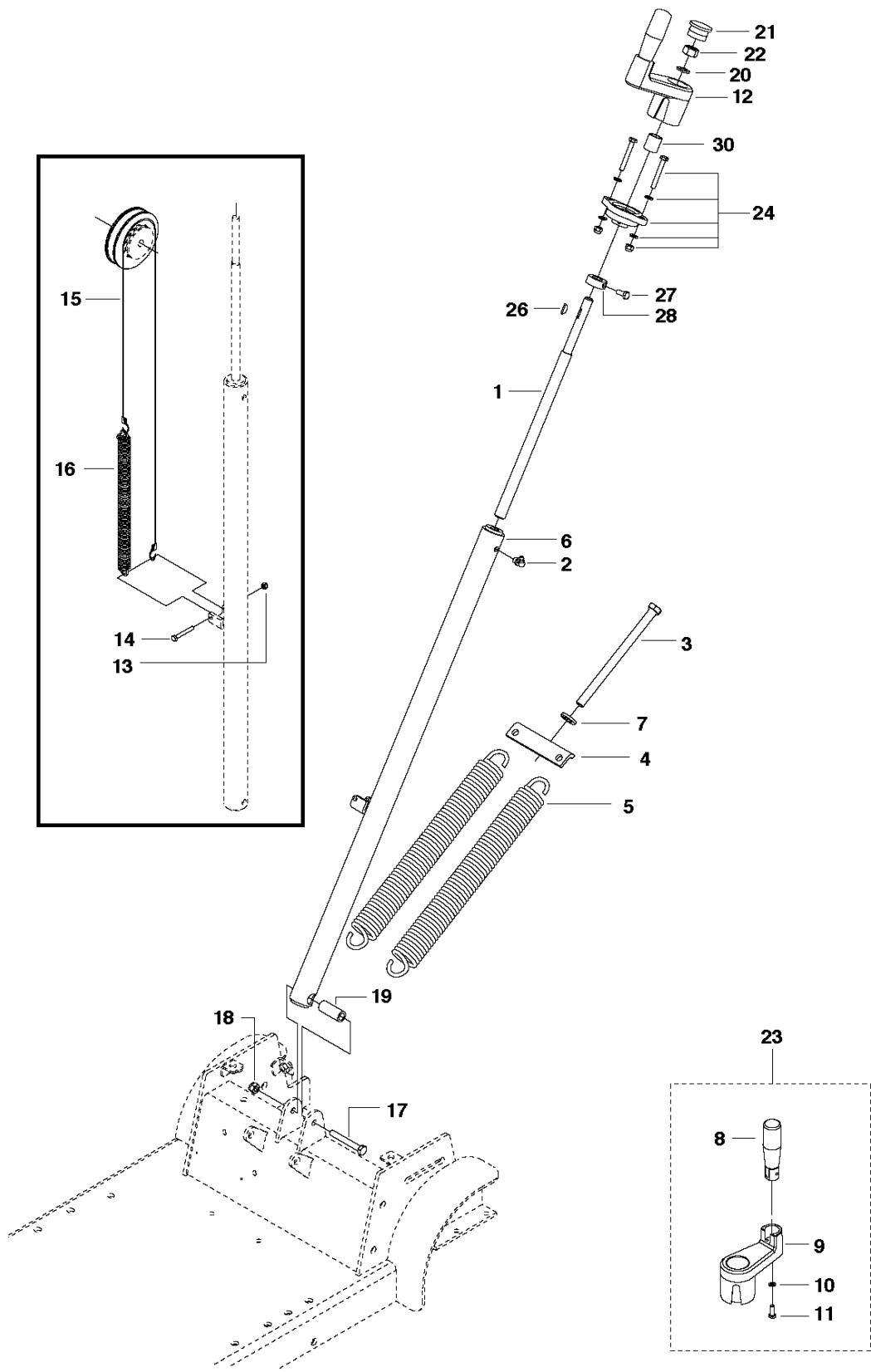

HEIGHT ADJUSTMENT FS513/FS520/FS524, Valid for Machine numbers FS520-2150, FS524-1630 and forward, 2011-02

Ref	Part No	Description	Remark	QTY	KIT
1	542 20 41-14	SCREW		1	
2	543 04 54-58	GRAISSEUR LAITON 31PR8MM/		1	
3	542 20 23-00	HHCS M12X1.75X190 G8.8 DIN 933		1	
4	542 20 21-66	BRACKET		1	
5	542 20 21-65	SPRING		2	
6	541 20 72-09	WELDMENT. SCREW TUBE. BLACK		1	
7	734 11 78-01	WASHER		1	
8	541 20 71-76	HAND CRANK ASSEMBLY		1	23
9	504 20 75-01	HANDLE		1	23
10	734 11 46-01	WASHER		1	23
11	725 23 29-71	SCREW EHHM		1	23
12	541 20 71-61	HANDLE		1	
13	732 25 16-01	HEXAGON LOCKING NUT		1	
14	725 23 79-51	SCREW EHHM		1	
15	542 20 41-16	CABLE ASSY		1	
16	542 20 22-83	SPRING		1	
17	725 25 03-51	SCREW EHHM		1	
18	732 25 20-01	HEXAGON LOCKING NUT		1	
19	542 20 23-79	BUSHING		1	
20	734 11 78-01	WASHER		1	
21	543 04 60-31	EMBOUT P NOIR D/35/		1	
22	539 99 02-58	NUT		1	
24	585 57 50-01	BEARING KIT		1	
23	541 20 71-61	HANDLE		1	
26	539 30 00-92	WOODRUFF KEY		1	
27	725 24 47-71	SCREW EHHM		1	
28	542 20 23-38	COLLAR. SCREW. Z/P		1	
30	542 20 40-83	SPACER		1	

LOWER FRAMING FS513/FS520/FS524, Valid for Machine numbers FS520-2150, FS524-1630 and forward, 2011-02

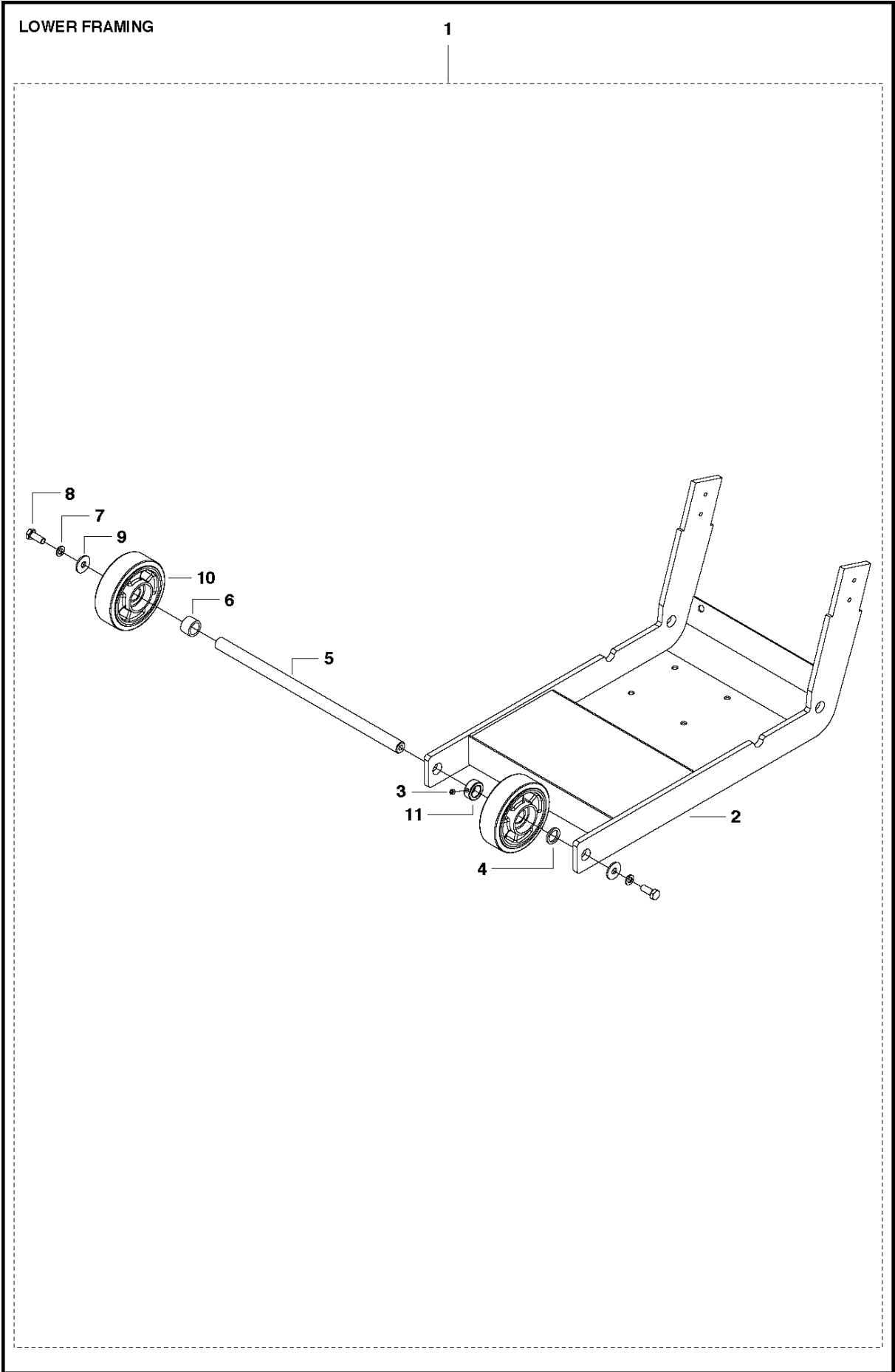

LOWER FRAMING FS513/FS520/FS524, Valid for Machine numbers FS520-2150, FS524-1630 and forward, 2011-02

Ref	Part No	Description	Remark	QTY	KIT
1	501 04 87-01	FRAME		1	
2	501 04 76-02	FRAME		1	1
3	542 13 97-68	SHSS. M8 X 6 DIN 916 GR12.9		1	1
4	542 20 20-62	WASHER		1	1
5	501 04 83-01	AXLE		1	1
6	501 04 85-02	SPACER		1	1
7	735 11 73-01	SPRING WASHER		2	1
8	725 24 93-71	SCREW EHHM		2	1
9	734 11 74-41	WASHER		2	1
10	543 04 59-49	WHEEL		2	1
11	542 20 24-23	COLLAR		1	1

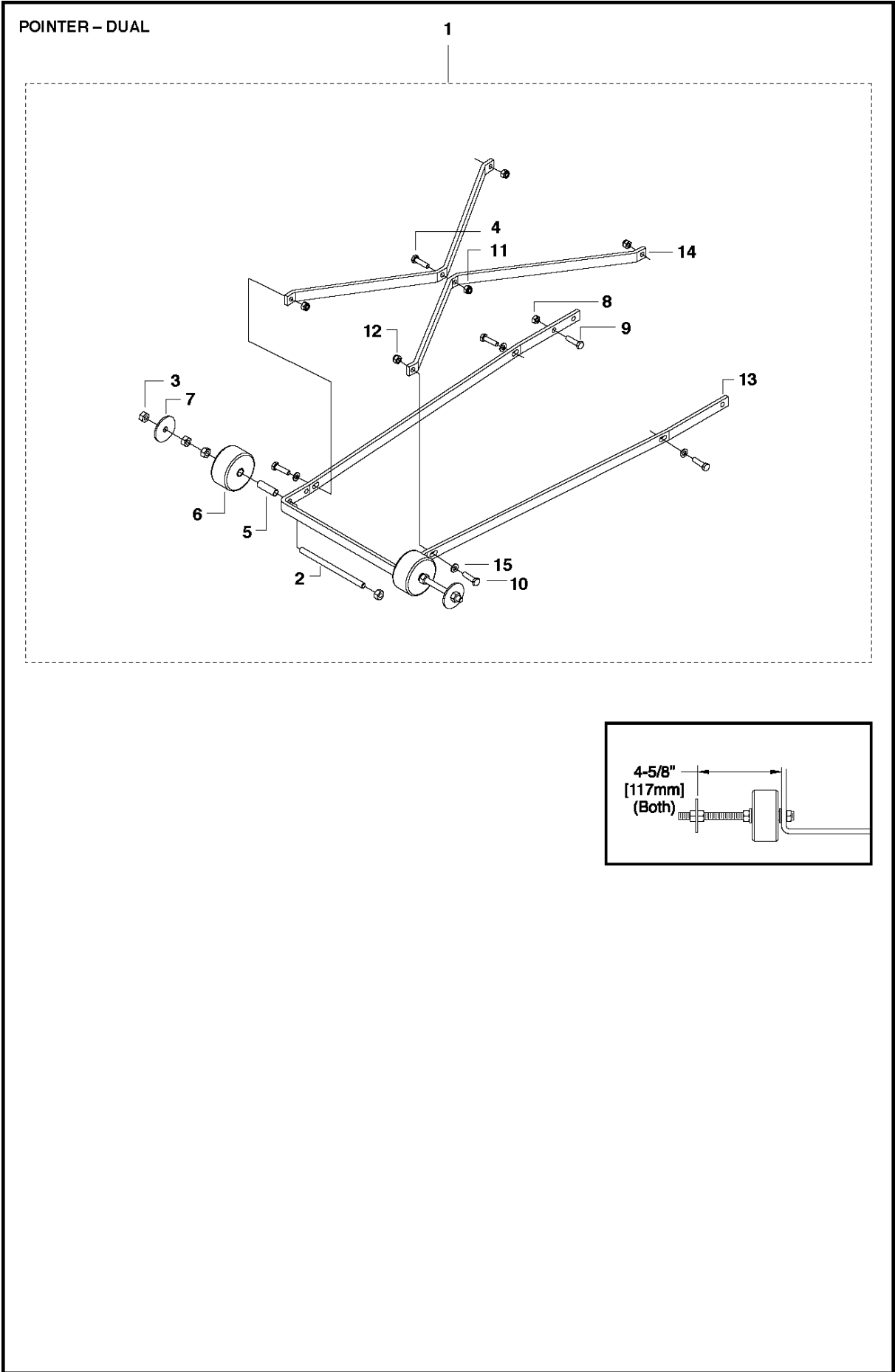

POINTER - DUAL FS513/FS520/FS524, Valid for Machine numbers FS520-2150, FS524-1630 and forward, 2011-02

Ref	Part No	Description	Remark	QTY	KIT
1	542 20 22-70	POINTER. DUAL. ASSY		8	
2	542 20 20-77	ROD		2	1
3	731 23 20-01	HEXAGON NUT		1	1
4	725 24 55-71	SCREW EHHM		4	1
5	542 20 20-75	BUSHING		2	1
6	543 04 59-32	WHEEL		2	1
7	542 20 21-06	WASHER		2	1
8	731 23 18-01	HEXAGON NUT		1	1
9	725 24 55-71	SCREW EHHM		1	1
10	725 24 55-71	SCREW EHHM		1	1
11	732 25 18-01	HEXAGON LOCKING NUT		1	1
12	732 25 18-01	HEXAGON LOCKING NUT		4	1
13	542 20 22-71	BAR. OUTSIDE. FINISHED		1	1
14	542 20 22-74	BAR PLATE		2	1
15	734 11 63-01	WASHER		4	1

POINTER - SINGLE FS513/FS520/FS524, Valid for Machine numbers FS520-2150, FS524-1630 and forward, 2011-02

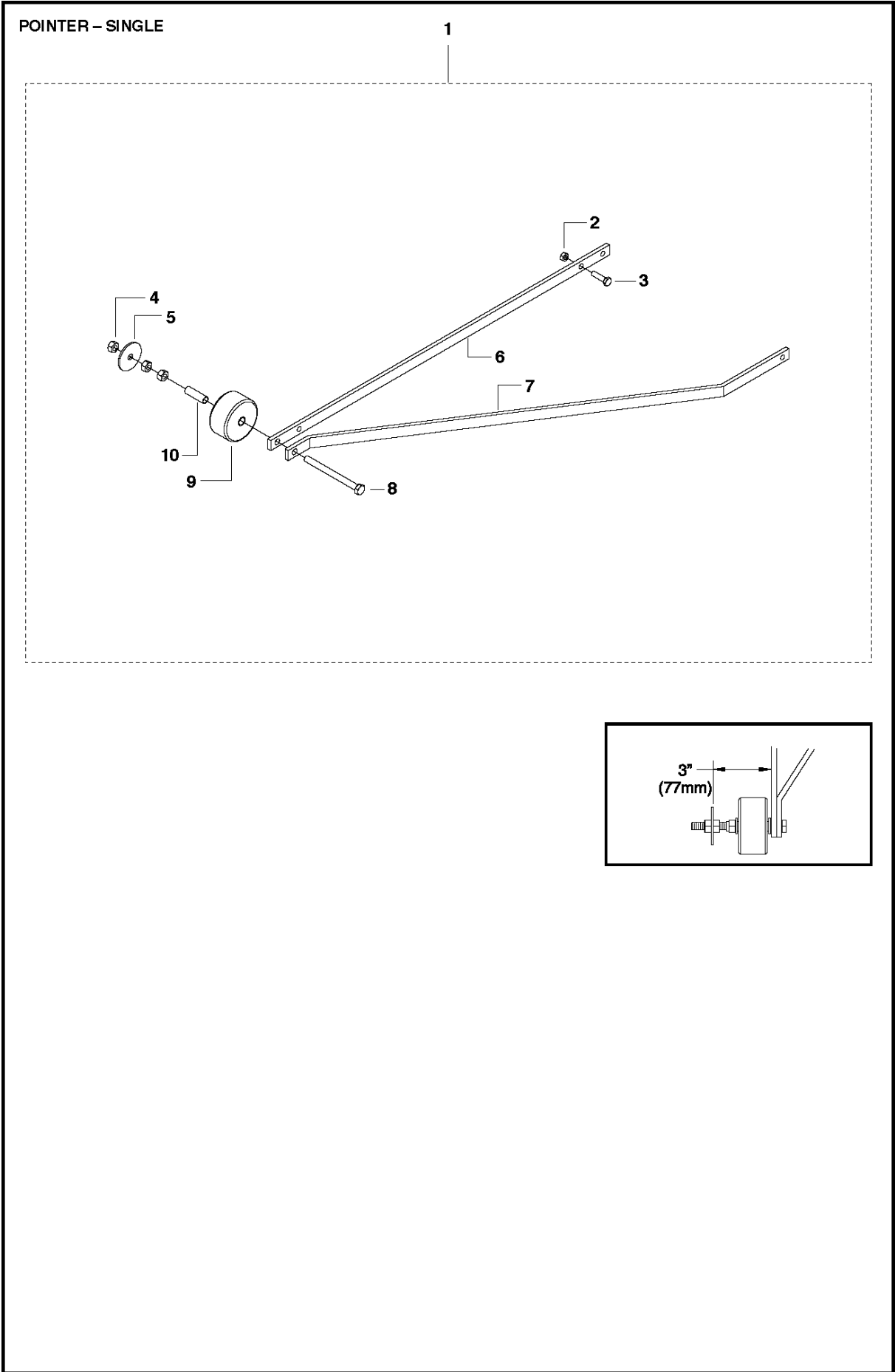

POINTER - SINGLE FS513/FS520/FS524, Valid for Machine numbers FS520-2150, FS524-1630 and forward, 2011-02

Ref	Part No	Description	Remark	QTY KIT
1	542 20 20-78	POINTER ASSY		1
2	731 23 18-01	HEXAGON NUT		1
3	725 24 55-71	SCREW EHHM		1
4	731 23 20-01	HEXAGON NUT		3
5	542 20 21-06	WASHER		1
6	542 20 21-31	BAR. STRAIGHT. FINISHED		1
7	542 20 21-30	BAR. BENT. FINISHED		1
8	725 25 15-71	SCREW EHHM		1
9	543 04 59-32	WHEEL		1
10	542 20 20-75	BUSHING		1

POINTER ATTACHMENT - DUAL POINTER

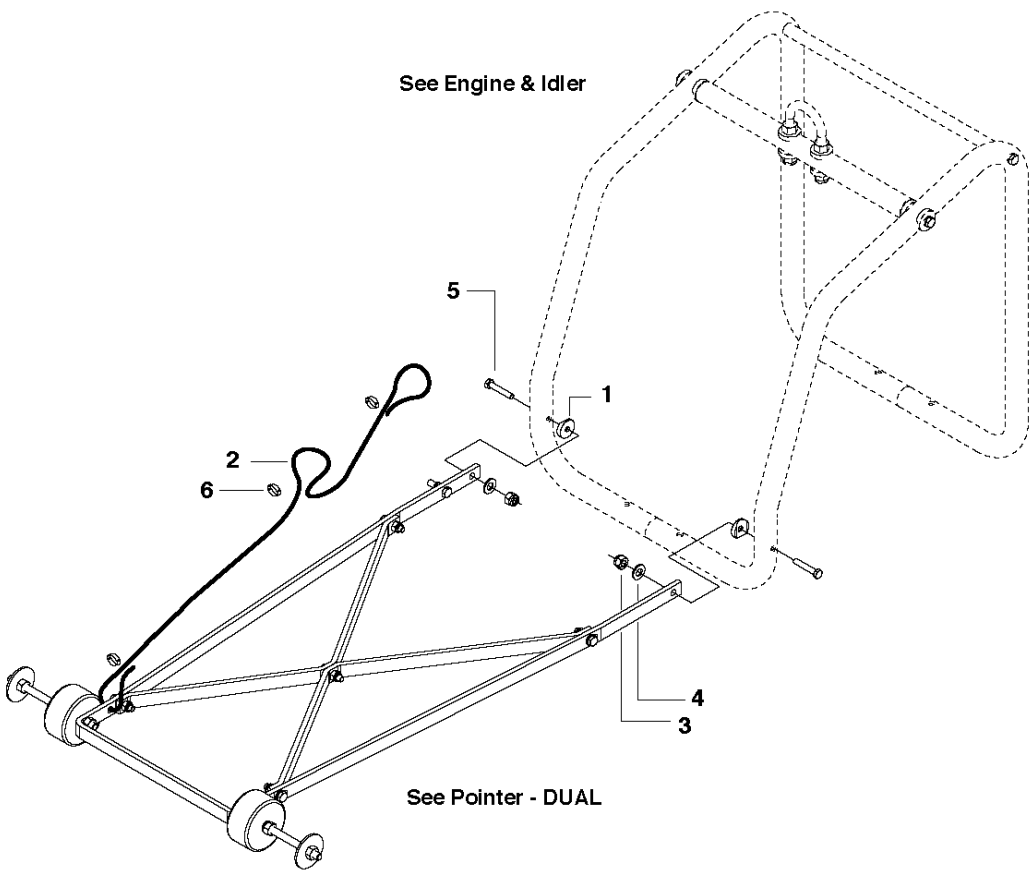

POINTER ATTACHMENT - DUAL POINTER
FS520-2150, FS524-1630 and forward, 2011-02

FS513/FS520/FS524, Valid for Machine numbers

Ref	Part No	Description	Remark	QTY KIT
1	542 20 21-84	WASHER		2
2	578 07 74-01	ROPE		
3	732 25 18-01	HEXAGON LOCKING NUT		2
4	734 11 63-01	WASHER		2
5	725 64 61-01	SCREW IHCSFM		2
6	542 16 27-61	CLAMP. CORD		3

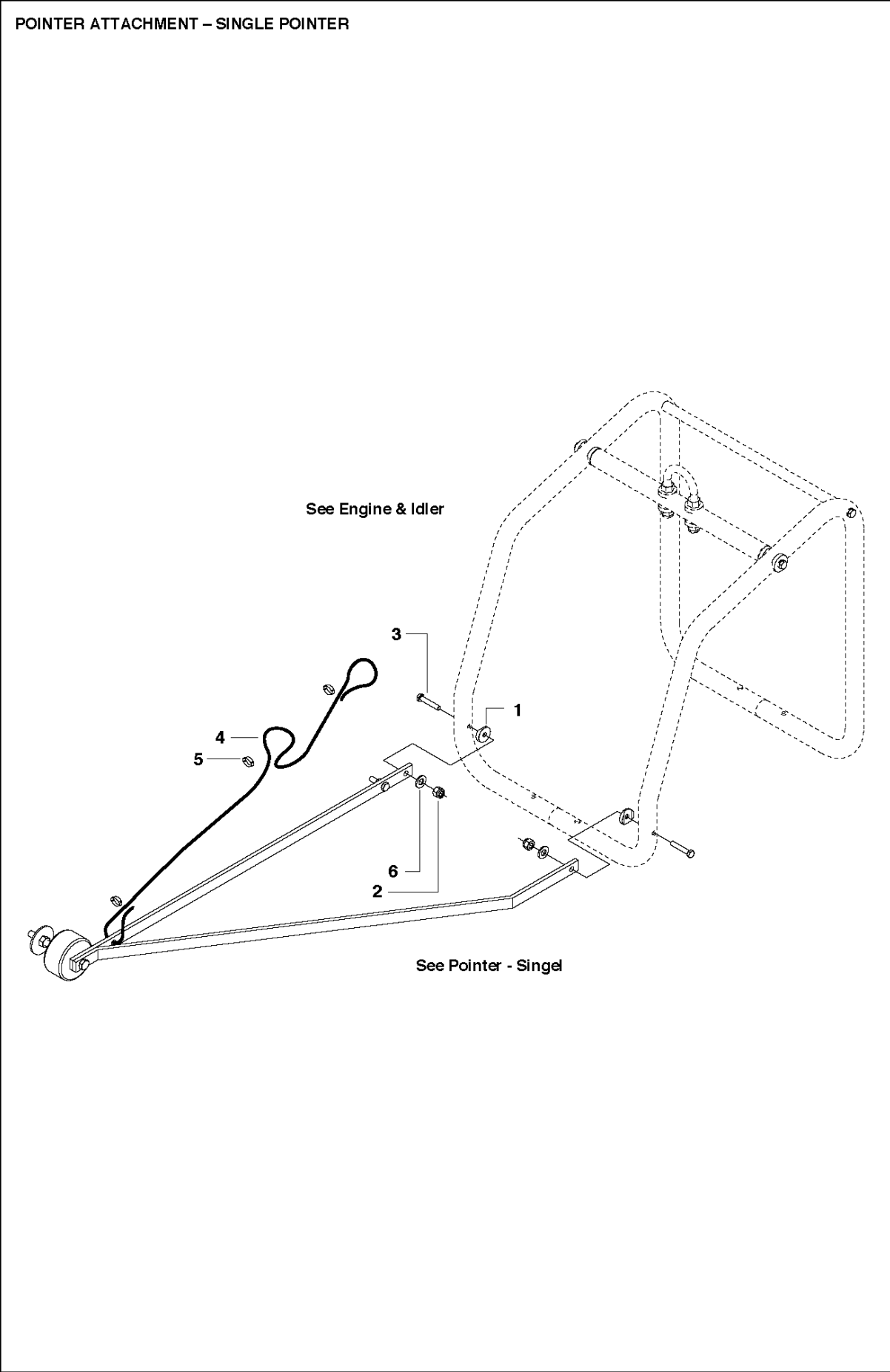

POINTER ATTACHMENT - SINGLE POINTER
FS520-2150, FS524-1630 and forward, 2011-02

FS513/FS520/FS524, Valid for Machine numbers

Ref	Part No	Description	Remark	QTY KIT
1	542 20 21-84	WASHER		2
2	732 25 18-01	HEXAGON LOCKING NUT		2
3	725 64 61-01	SCREW IHCSFM		2
4	578 07 74-01	ROPE		
5	542 16 27-61	CLAMP. CORD		3
6	734 11 63-01	WASHER		2

TOOLBOX 20, 24 HP

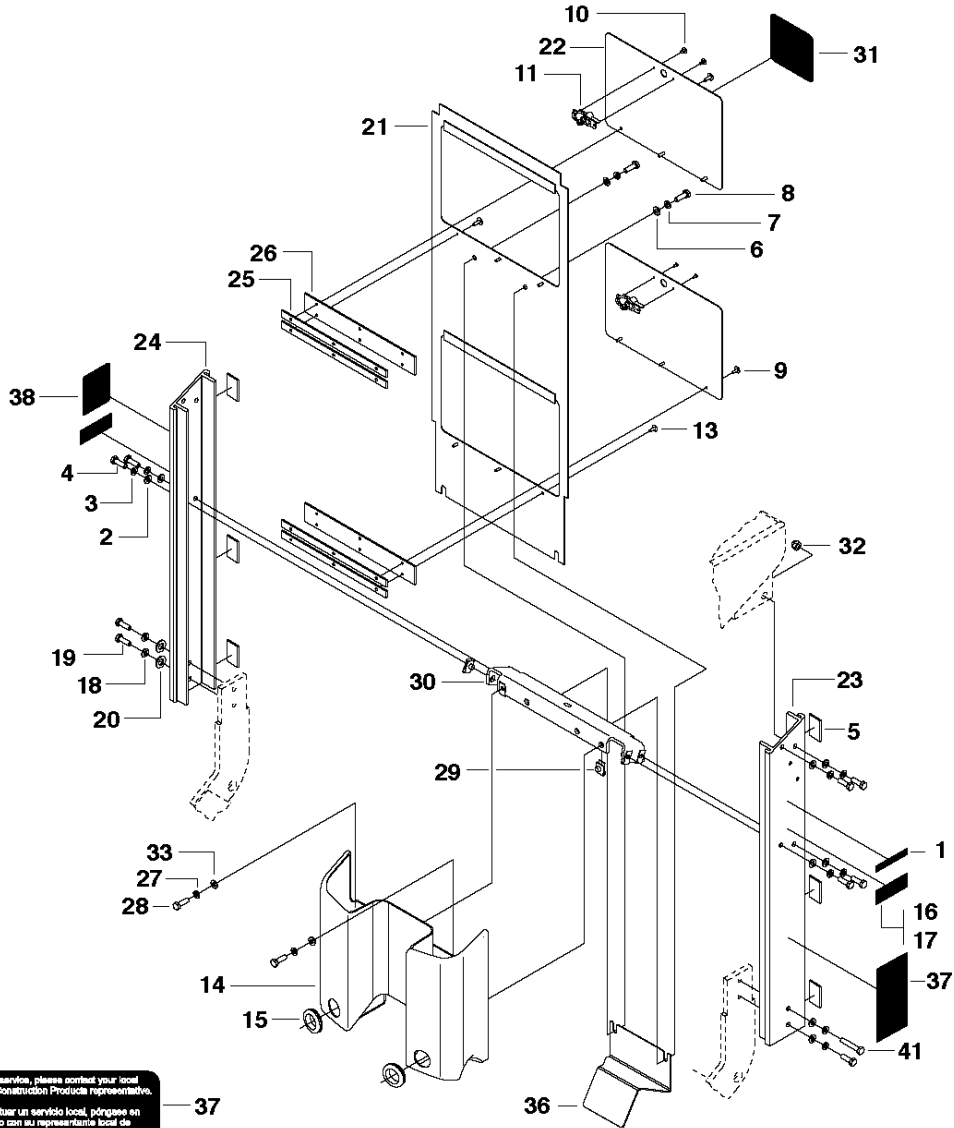

For local service, please contact your local Husqvarna Construction Products representative.

Para efectuar un servicio local, póngase en contacto con su representante local de Husqvarna Construction Products.

Pour toute réparation, contactez le représentant local de Husqvarna Construction Products.

Für Service vor Ort wenden Sie sich bitte an Ihren örtlichen Makler von Husqvarna Construction Products.

Neem voor plaatselijke service contact op met uw plaatselijke vertegenwoordiger van de constructieproducten van Husqvarna.

Per assistenza, rivolgersi al rappresentante di zona della Husqvarna Construction Products.

För service på platsen, kontakta din lokala representant för Husqvarna Construction Products.

Para obter serviço técnico local, contate o representante da Husqvarna Construction Products local.

Europe / Europe:
Husqvarna
Construction Products
65-433 81 Partille, Sweden
Tel: +46 31 84 90 00
Fax: +46 31 84 90 50

Asia Pacific:
Husqvarna
Construction Products,
Australia Pty Ltd
25-31 Kiriaki Avenue,
North Plympton, Adelaide,
South Australia, 5037
Tel: +61 (0)8 8375 1000
Fax: +61 (0)8 8371 0990

The Americas:
Husqvarna Construction Products,
North America
17400 West 119th Street,
Olathe, Kansas 66061 USA
Toll-Free Telephone: 800-238-8040,
Telephone: 816-928-1900
Fax: 816-438-1930



16
FS 520

17
FS 524

12
PATENT PENDING

31

WARNING

Read And Understand Entire Operation Manual Before Operating Machine!

Understand All Warnings, Instructions & Controls Before Operating Machine!

Operation Manual Located Within Machine As Shown Below.

TOOLBOX FS513/FS520/FS524, Valid for Machine numbers FS520-2150, FS524-1630 and forward, 2011-02

Ref	Part No	Description	Remark	QTY KIT
1	542 16 12-35	DECAL		1
2	734 11 63-01	WASHER		2
3	735 11 64-01	SPRING WASHER		2
4	725 24 53-71	SCREW EHHM		2
5	542 20 23-07	PAD. RESILIENT		6
6	734 11 63-01	WASHER		2
7	735 11 64-01	SPRING WASHER		2
8	725 24 53-71	SCREW EHHM		4
9	722 79 44-02	RIVET		6
10	722 78 18-03	BLIND RIVET		4
11	541 20 82-81	LATCH		2
12	542 16 12-35	DECAL		1
13	722 79 44-02	RIVET		6
14	501 13 93-01	CYLINDER COVER		1
15	586 58 07-01	GROMMET		2
16	542 19 07-09	DECAL		1
17	542 19 07-10	DECAL		1
18	735 11 64-01	SPRING WASHER		4
19	725 24 53-71	SCREW EHHM		3
20	734 11 63-01	WASHER		5
21	542 20 41-67	COVER		1
22	542 20 23-50	DOOR. TOOLBOX - H. ORG		2
23	542 20 23-49	SIDE LEFT - H. ORG.		1
24	542 20 23-48	SIDE RIGHT - H. ORG.		1
25	542 20 21-71	PLATE. RIVET. Z/P		4
26	541 20 82-78	HINGE		2
27	735 11 64-01	SPRING WASHER		4
28	725 24 53-71	SCREW EHHM		4
29	542 20 20-99	U-NUT. M8X1.25(1.5-5.5MM MATL)		8
30	542 20 23-52	BOTTOM. TOOLBOX- H. ORG.		1
31	542 19 05-93	DECAL		1
32	732 25 18-01	HEXAGON LOCKING NUT		4
33	734 11 63-01	WASHER		4
36	542 20 41-74	BRACKET		1
37	542 19 06-46	DECAL		1
38	578 01 42-01	DECAL		1
41	725 24 60-71	SCREW EHHM		1

TOOLBOX 13 HP

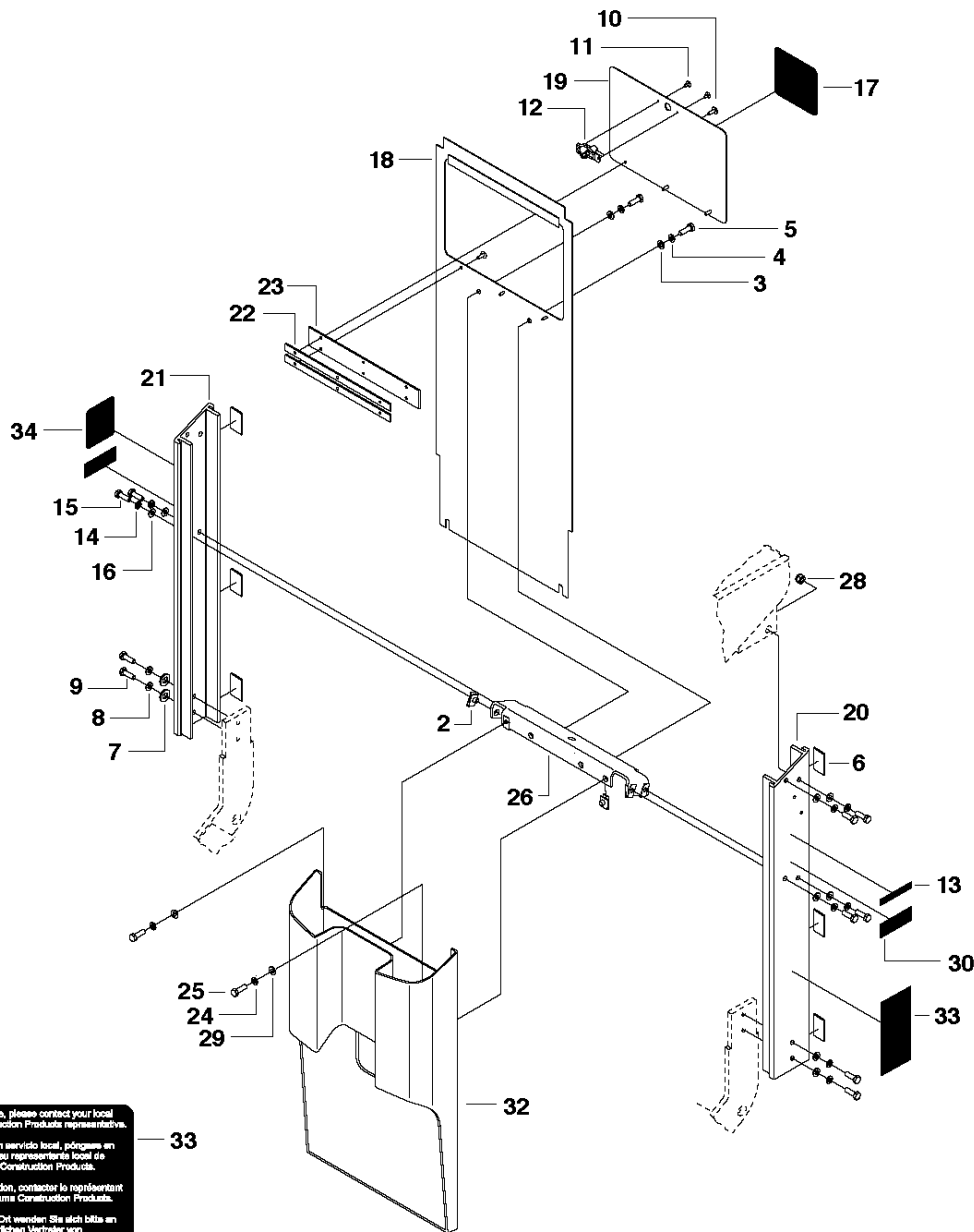

For local service, please contact your local Husqvarna Construction Products representative.

Para efectuar un servicio local, póngase en contacto con el representante local de Husqvarna Construction Products.

Pour toute réparation, contactez le représentant local de Husqvarna Construction Products.

Für Service vor Ort wenden Sie sich bitte an Ihren örtlichen Vertreter von Husqvarna Construction Products.

Neem voor plaatselijk service contact op met uw plaatselijke vertegenwoordiger van de constructieproducten van Husqvarna.

Per assistenza, rivolgersi al rappresentante di zona della Husqvarna Construction Products.

För service på platsen, kontakta din lokala representant för Husqvarna Construction Products.

Para obter serviço técnico local, contacte o representante da Husqvarna Construction Products local.

Europe / Europe:
Husqvarna
Construction Products
SE-423 81 Partla, Sweden
Tel: +46 31 94 90 00
Fax: +46 31 94 90 00

Asia Pacific:
Husqvarna
Construction Products,
Australia Pty Ltd
25-31 Kinross Avenue,
North Plympton, Adelaide,
South Australia 5037
Tel: +61 08 8376 1000
Fax: +61 08 8371 0990

The Americas:
Husqvarna Construction Products,
North America
17400 West 110th Street,
Olathe, Kansas 66061 USA
Tel-Free Telephone: 800-288-6040,
Telephone: 913-628-1990
Fax: 913-483-7988



34
30
FS 513

1
PATENT PENDING

27

WARNING

Read And Understand Entire Operation Manual Before Operating Machine!

Understand All Warnings, Instructions & Controls Before Operating Machine!

Operation Manual Located Within Machine As Shown Below.

TOOLBOX FS513/FS520/FS524, Valid for Machine numbers FS520-2150, FS524-1630 and forward, 2011-02

Ref	Part No	Description	Remark	QTY KIT
1	542 16 12-35	DECAL		1
2	542 20 20-99	U-NUT. M8X1.25(1.5-5.5MM MATL)		8
3	734 11 63-01	WASHER		2
4	735 11 64-01	SPRING WASHER		2
5	725 24 53-71	SCREW EHHM		2
6	542 20 23-07	PAD. RESILIENT		6
7	734 11 63-01	WASHER		2
8	735 11 64-01	SPRING WASHER		2
9	725 24 53-71	SCREW EHHM		4
10	722 79 44-02	RIVET		3
11	722 78 18-03	BLIND RIVET		4
12	541 20 82-81	LATCH		2
13	542 16 12-35	DECAL		1
14	735 11 64-01	SPRING WASHER		4
15	725 24 53-71	SCREW EHHM		4
16	734 11 63-01	WASHER		4
17	542 19 05-93	DECAL		1
18	504 20 21-03	COVER		1
19	542 20 23-50	DOOR. TOOLBOX - H. ORG		2
20	542 20 23-49	SIDE LEFT - H. ORG.		1
21	542 20 23-48	SIDE RIGHT - H. ORG.		1
22	542 20 21-71	PLATE. RIVET. Z/P		4
23	541 20 82-78	HINGE		2
24	735 11 64-01	SPRING WASHER		4
25	725 24 53-71	SCREW EHHM		4
26	542 20 23-52	BOTTOM. TOOLBOX- H. ORG.		1
27	542 19 05-93	DECAL		1
28	732 25 18-01	HEXAGON LOCKING NUT		4
29	734 11 63-01	WASHER		4
30	542 19 07-08	DECAL		2
32	502 28 91-01	COVER		1
33	542 19 06-46	DECAL		1
34	578 01 42-01	DECAL		1

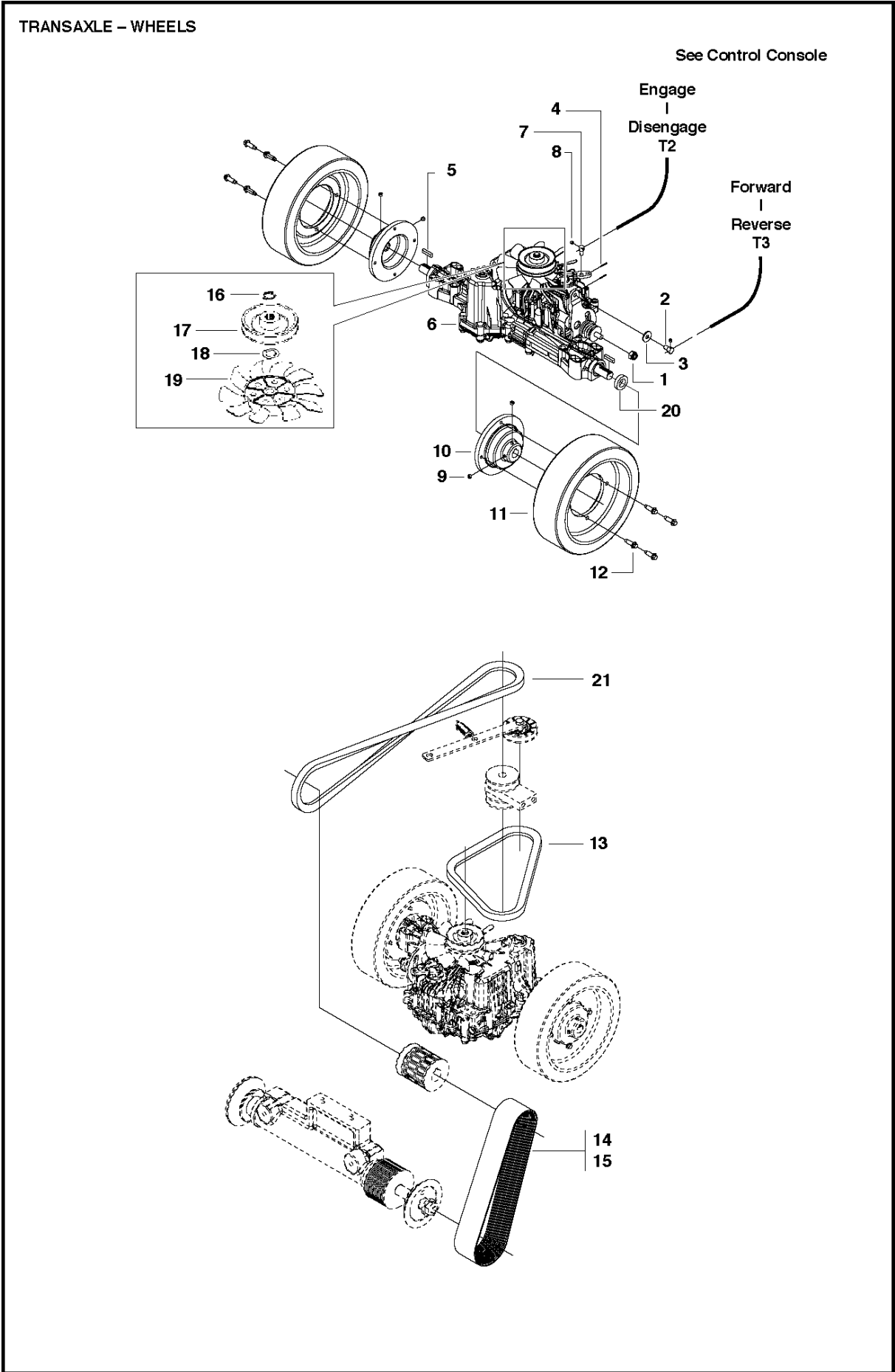

TRANSAXLE - WHEELS FS513/FS520/FS524, Valid for Machine numbers FS520-2150, FS524-1630 and forward, 2011-02

Ref	Part No	Description	Remark	QTY KIT
1	732 25 20-01	HEXAGON LOCKING NUT		1
2	542 20 23-32	PIN. PIVOT		1
3	734 11 63-01	WASHER		1
4	721 61 51-01	STIFT 2 X 14 DIN94		2
5	542 20 41-43	KEY		2
6	541 20 83-38	TRANSAXLE. MODIFIED		1
7	542 20 23-31	PIN. PIVOT		1
8	542 13 97-69	SHSS. M6 X 6 DIN916 GR 12.9		2
9	542 13 97-68	SHSS. M8 X 6 DIN 916 GR12.9		4
10	541 20 72-34	HUB		2
11	586 44 28-01	WHEEL		2
12	542 19 90-53	HWH BODY BOLT W/DOG/PT M8-1.25		8
13	542 20 41-17	BELT		1
14	542 20 21-50	STRAP	FS 513 -18&20"	1
15	504 06 83-01	BELT	FS 520 - 20", FS 524 - 24"	1
16	506 98 65-01	SPRING WASHER		1
17	510 18 58-01	PULLEY		1
18	735 31 15-00	CIRCLIP		1
19	510 18 57-01	FAN		1
20	535 40 28-37	SEALING		1
21	510 23 72-01	V-BELT		1

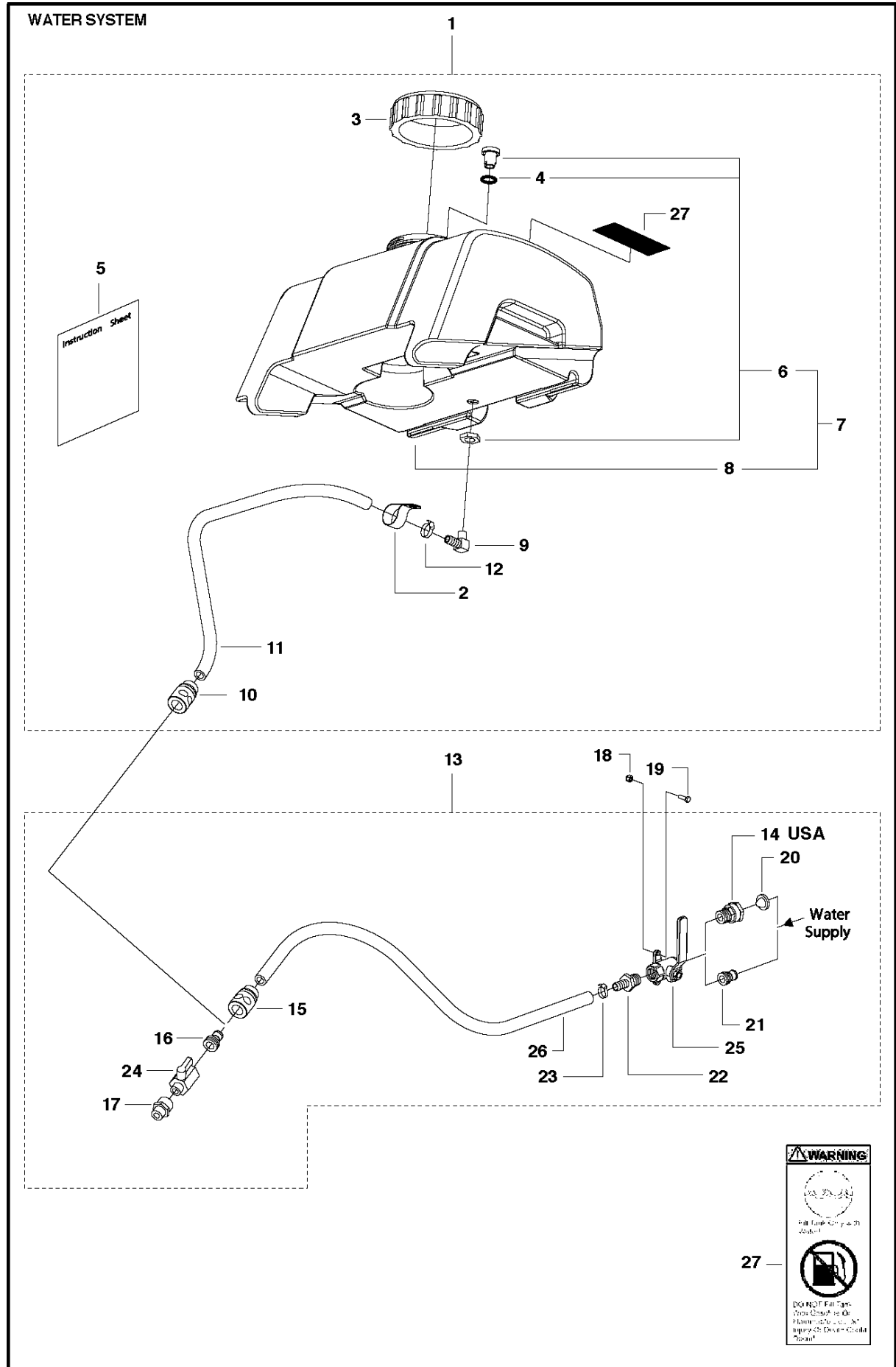

WATER SYSTEM FS513/FS520/FS524, Valid for Machine numbers FS520-2150, FS524-1630 and forward, 2011-02

Ref	Part No	Description	Remark	QTY	KIT
1	541 20 82-86	WATER TANK ASSEMBLY		1	
2	542 20 23-11	BRACKET		1	1
3	541 20 82-84	HUB CAP		1	1
4	542 19 61-83	O-RING		1	1, 6, 7
5	542 20 11-23	INSTR SHEET:WATER TANK INSTALL		1	1
6	542 19 61-84	ASSY. TANK FITTING		1	1, 7
7	542 20 23-20	TANK		1	1
8	542 20 20-93	TANK		1	1, 7
9	543 85 01-31	FITTING		1	1
10	543 04 56-12	RACCORD RAPIDE LAITON/D/15 535		1	1
11	576 19 93-03	HOSE		1	1
12	543 85 03-44	CLIP		1	1
13	542 20 23-15	WATER. SIDE ASSY		1	
14	542 20 23-08	FITTING	USA only	1	13
15	543 04 56-12	RACCORD RAPIDE LAITON/D/15 535		1	13
16	543 04 56-10	ADAPT RAPIDE MALE 15X21/		1	13
17	542 20 23-40	FITTING		1	13
18	732 25 12-01	HEXAGON LOCKING NUT		2	
19	725 22 95-71	SCREW EHHM		2	
20	542 04 56-40	FS900T RING/	USA only	1	13
21	543 85 03-59	ADAPTER		1	13
22	542 20 23-21	FITNG 1/2" MNPT X 12 DIA BARB		1	13
23	543 85 03-44	CLIP		1	13
24	543 04 55-39	ROBINET MINU-LUX 1/2 MXF/		1	13
25	505 21 34-01	VALVE		1	13
27	542 19 06-17	DECAL		1	13
26	576 19 93-02	HOSE		1	13

WATER TANK & NOSE PIECE 13 HP

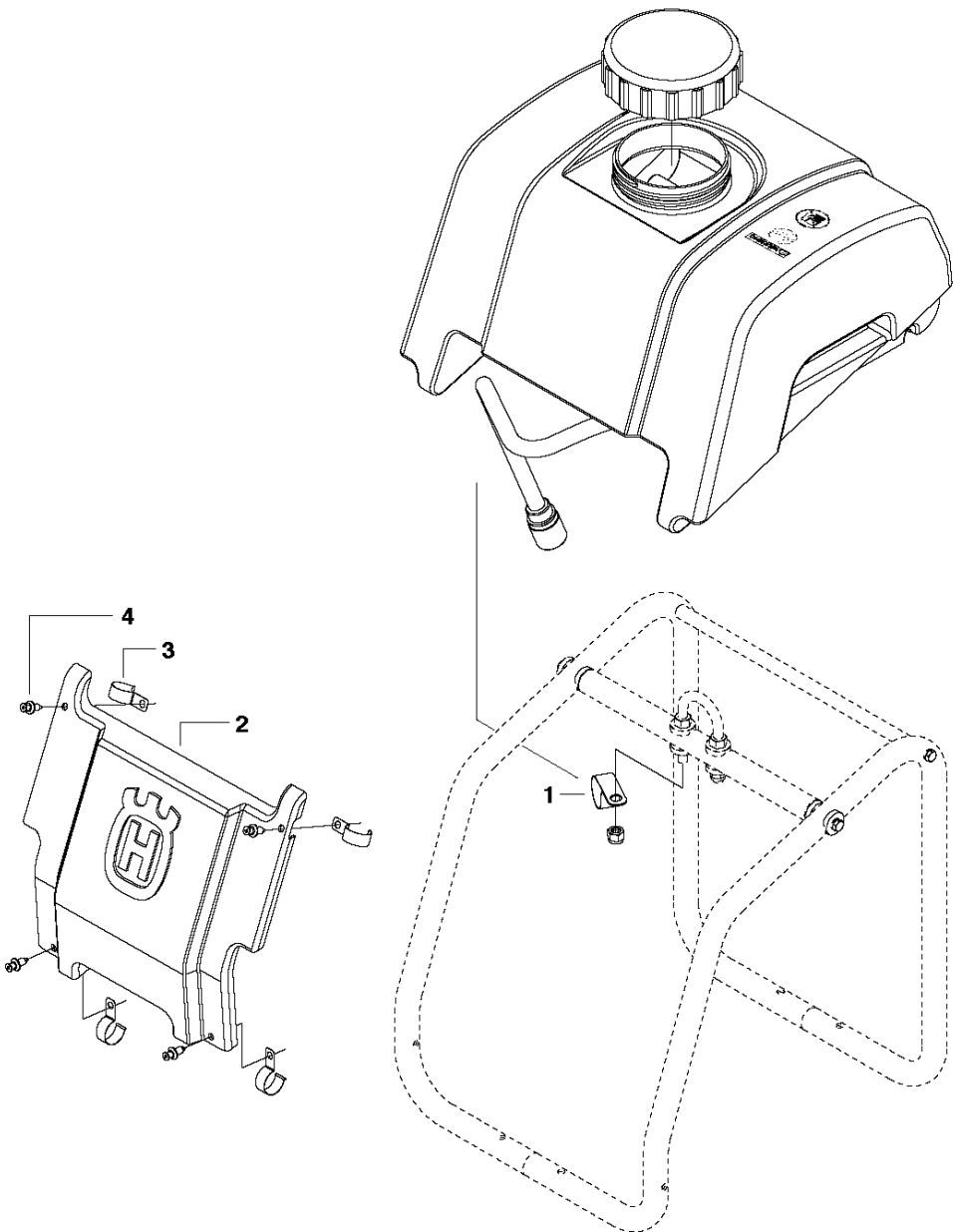

WATER TANK & NOSE PIECE
FS524-1630 and forward, 2011-02

FS513/FS520/FS524, Valid for Machine numbers FS520-2150,

Ref	Part No	Description	Remark	QTY KIT
1	542 20 23-11	BRACKET		1
2	542 20 41-49	NOSE PIECE - HUSQVARNA		1
3	542 20 21-28	CLIP		4
4	542 16 66-24	BOLT		4

WATER TANK & NOSE PIECE 20, 24 HP

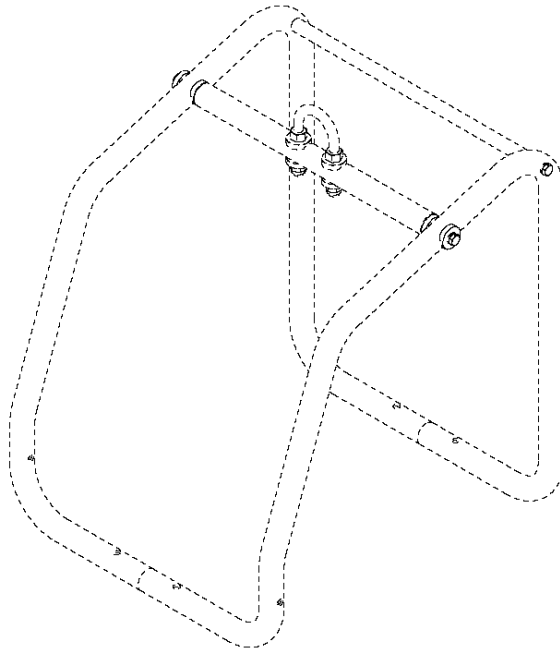
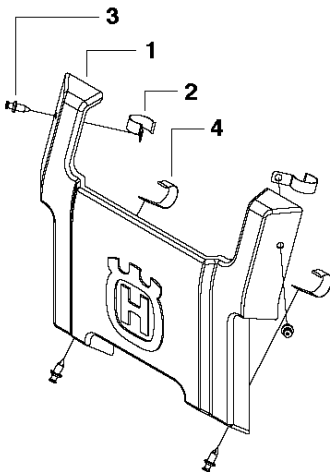
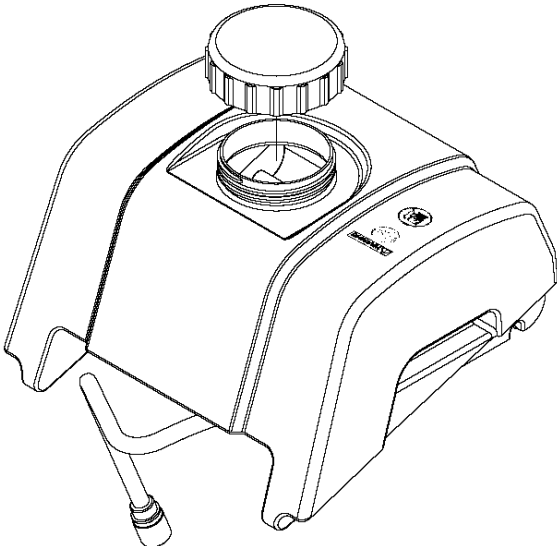

WATER TANK & NOSE PIECE
FS524-1630 and forward, 2011-02

FS513/FS520/FS524, Valid for Machine numbers FS520-2150,

Ref	Part No	Description	Remark	QTY KIT
1	542 20 41-50	NOSE PIECE - HUSQVARNA		1
2	542 20 21-28	CLIP		2
3	542 16 66-24	BOLT		4
4	504 10 11-02	CLIP		2